

XXVII. *A general Theory for the Mensuration of the Angle subtended by Two Objects, of which One is observed by Rays after Two Reflections from plane Surfaces, and the other by Rays coming directly to the Spectator's Eye.* By George Atwood, M. A. F. R. S.

Read June 21, 1781.

THE actual determination of an angle implies two observations, one taken at each extremity of the arc by which that angle is measured. When fixed astronomical quadrants or other sectors are used for the practical estimation of angles, one of these observations is previously made by directing the axis of the telescope or line of collimation to some fixed point in the heavens, the index being then coincident with the initial point on the arc of the sector: after this adjustment one observation only is necessary to ascertain the angular distance.

distance between that point and any other celestial object in the plane of the sector. This method, however, is evidently impracticable, unless the instrument can be steadily fixed; for which reason astronomical quadrants become useless at sea; and from the difficulties which attend placing them in their due position and adjustment on firm ground, they are almost wholly confined to regular observatories.

Mr. HADLEY *, by an ingenious application of optical principles, contrived to bring both extremities of the arc measured into the field of the spectators's view at the same time; by which improvement, angles are taken at sea, as well as on land with an unfixed instrument, to a degree of accuracy sufficient for nautical and other purposes, when the utmost exactness is not required.

Mr. HADLEY'S invention is a particular case of a very extensive theory, as yet but little attended to. According to his method, which is well known, the two reflecting surfaces used in the observation are perpendicular to the plane of motion; the direction of the telescope, and of the rays passing between the reflectors being parallel to that plane; whereas the inclination of the telescope, and of the intermediate rays, as well as of the reflectors themselves to the plane of motion, admits of unlimited variety. A general theory to determine the angle observed by two reflections from the data on which its magnitude depends, without limitation or restriction, seems applicable to several useful purposes in practical astronomy. Having never seen any geometrical construction or analysis of this curious problem, I was induced to bestow some consideration

* Phil. Transf. N^o 420. See also a tract, intituled, *The Theory of HADLEY'S quadrant*, by the rev. W. LUDLAM.

on the subject, and shall be happy if the result of my inquiries appears to merit the attention of the Royal Society.

Art. 1. The manner of taking an observation by two reflections unconfined to any particular case may be described thus. Let C, B (fig. 1.) represent two plane reflecting surfaces, inclined to a plane OPA at any given angle. Through any point of the reflecting surface C draw a line perpendicular to the plane OPA, and with the point where the line meets the plane as a centre (which must here be represented by C) and any distance CP, describe a circle OPA. The reflecting plane B always continuing fixed, let the reflector C be moveable along with the radius CP as it revolves in the plane OPA round the centre C: the angular motion of the speculum C, referred to the circumference OPA, will be measured by the arc which the radius CP describes, the inclination of the plane C to the plane of motion OPA being always the same, and equal to that of the fixed speculum B.

2. The two plane reflectors, B and C, being equally inclined to the plane OPA, it follows, that during the motion of C there must be some point O in the circumference OAP, at which when CP arrives, the reflector C will be parallel to the fixed reflector B.

3. When the moveable radius which carries round the plane C is at any other position CP, let a ray flowing from a distant object T impinge on the speculum C; let it be reflected from thence in the direction CB, and being again reflected at B in the direction BG, let it be observed by a spectator's eye at G; the image of T will appear somewhere in the line GBS; suppose that a ray flows from a distant object S situated in the line GB produced, and that this ray SG comes directly to the spectator's

eye at G: the object S seen by direct rays, and the image of the point T seen by rays after two reflections, will appear to coincide in the line GBS. This is an observation by two reflections, from which, together with such data as limit the problem, the true angle subtended by the objects T and S is to be inferred.

4. The data which limit this problem, being necessary for the determination of the angle subtended by T and S are in number four, which are next to be considered. 1st. One of these data is the arc PO, being the angular distance of the moveable radius CP, measured on the circumference of the circle OPA, from that position CO, at which the two reflectors are parallel; the situation of this arc OP in respect of the point O being supposed known, that is, it being known on which side of that point, OP is situated in respect of the ray BG. 2^{dly}, The common inclination of the reflecting planes B and C to the plane of motion is another of these data. The third and fourth of the conditions must be mentioned rather more particularly. The ray BG is always understood to be given in position in respect of the plane of motion OPA (considered as immoveable) being either coincident with the line of collimation of a telescope, or directed by sights so as to be invariably fixed: the speculum B also being unmoved, the line or ray BC will never change its position, from the known principles of reflection. The angle CBG, therefore, and the half of that angle being the angle of incidence at which CB impinges on B, will be always of the same magnitude; whereas the half of the angle BCT, or the angle of incidence on the moveable speculum C, is continually changing, while C is carried round in the plane of motion: this constant angle of incidence or reflection at the fixed speculum B will be another of the data necessary to determine the problem.

The

The rays GB, BC, and the speculum B, being fixed in respect of each other, and of the plane OAP, the plane CBG will also be given in position; that is, its inclination to the plane of motion, or to any other fixed plane, will constantly be the same: whereas the inclination of the plane BCT to the plane of motion, or other fixed plane, will be continually changing while the reflector C revolves with the radius CP. The position of the plane GBC constitutes the fourth and last of the data, and it will be immaterial to what fixed plane it is referred. In the ensuing solution the situation of this plane will be defined by its inclination to the fixed secondary of the plane of motion which passes through the point O.

5. The enumeration of these data leads to the construction of the problem, a few observations being previously inserted to prevent repetitions and unnecessary references. 1st, The objects observed are understood to be lucid or illumined points, and so distant, that the rays which flow from either of them may be esteemed parallel without error as far regards these observations: such objects are the fixed stars, any given points in the disks of the sun or planets, &c. 2^{dly}, As in measuring the angular positions of objects which lie in the same plane, these objects are referred to the circumference of a circle, the centre of which is coincident with the spectator's eye; so in estimating the positions of objects which lie in different planes, and of the inclinations of these planes to each other, the objects, &c. are referred to the circumference of a sphere, of which the centre coincides with the centre of the spectator's view: applying this to the present case, since the lines CT, CB, SG (fig. 1.) are situated in different planes; in order to estimate their positions, any point may be assumed as the centre of a sphere, and through that point lines are to be drawn parallel to the given lines CT, CB, SG, the points in

which the lines intersect the sphere's surface will give their relative situations by the rules of trigonometry. 3dly, There will be no necessity to represent the reflecting planes in the general construction, since the positions of the perpendiculars to the planes will give the situations of the planes themselves.

6. To determine by construction the angle subtended by the objects T, S, from the data which have been described, let APOCQ (fig. 2.) represent a great circle of the sphere to the surface of which the objects observed, and the positions of the incident and reflected rays, &c. are referred; C being the center, CK the axis, and K the pole of this great circle; through K draw any secondary KO, and from the pole K, at the distance of the arc KF, = the measure of the given inclination of the reflecting planes to the plane of motion, describe a parallel or lesser circle FIM: with the pole F, and at a distance equal to a quadrant, describe an arc of a great circle intersecting the secondary KO produced in the point X, and in this arc from X take XY = the measure of the given inclination of the fixed plane of reflection at the speculum B to the secondary which passes through the point O; and draw the quadrant YF, which produces in the direction YF: from F on either side of F set off FD equal to the measure of the given constant angle of incidence at the speculum B, and make FB (taken on that side of F which is opposite to D) equal to FD. Draw the radius CO: from O set off an arc OP in the circumference OPA equal to the measure of the angular distance described by the moveable radius CP from that position at which the reflectors are parallel; observing that the arc OP be on that side of the point O which * corresponds with the conditions of the problem (art. 4.): through P describe the secondary KP intersecting the parallel FIM in the point I: through B and I describe

* It is supposed to be known, whether CP beginning its motion from the position CO approaches towards the visual ray BG or recedes from it.

the arc of a great circle BIE, and in it take EI equal to IB: through D and E draw the arc of a great circle DE: the arc DE will be the measure of the true angle subtended by the objects observed, according to the data of the problem.

Previous to the demonstration of this construction, the application of it to the method of observation by two reflections should be described. Join CP, CI, and CF. To the extremity C of the radius CP let a plane speculum be affixed, CI being always perpendicular to this plane: as PC revolves in the plane of motion, the perpendicular CI will describe the parallel or lesser circle FIM, and when CP coincides with CO, CI will coincide with CF. Through B draw BR parallel to CF, and let a plane speculum be fixed at B perpendicular to BR; CF and BR being parallel when the perpendicular CI coincides with CF, the reflectors at C and B will then be parallel.

Join CD, and produce it to a very distant point S, and through B draw GBS parallel to CDS; the reflectors C and B being parallel, and their perpendiculars coinciding with CF and BR, let a ray SC impinge on the reflector C: because FC is the perpendicular to the speculum C and the arc DF = FB by construction, these arcs being in the plane of the same great circle DBQ, it follows, that the ray SC will be reflected from C in the direction CB, impinging on the speculum B at the angle of incidence CBR; and since DC and BG are parallel by construction, and the parallel lines FC BR fall on them, the angles RBG, FCD, will be equal, and FCB or CBR = RBG. CB therefore being the ray incident on the speculum B will be reflected in the direction BG parallel to SC; and a ray SG coming directly from S will be seen coincident with the reflected ray BG. Here we observe, that the planes of reflection at C and B, that is, the planes DCB and CBG coincide, the reflectors being parallel.

Let

Let the radius CP move from the position CO, carrying with it the speculum C and its perpendicular CI: then, EI being equal to IB by construction, a ray impinging on C in the direction TEC will be reflected in the plane ECB, and because $\angle ECI = \angle ICB$, the reflected ray will coincide with the line CB, and after reflection at B will * proceed in the direction BG, being coincident with the ray SG which comes directly from S. When the perpendicular CI leaves CF, the plane of reflection ICB becomes inclined to the plane of reflection DCBG with which it before coincided; but the position of the rays CB, BG, and of the perpendicular BR, remains unaltered; for which reason the plane GBCFD corresponds to the fixed plane of reflection described among the conditions (art. 4.). When CI was coincident with CF, the radius CP was coincident with CQ, O being the initial point of the arc OP, described by the radius CP, denoting that when CP coincides with O, the reflectors being then parallel, the inclination of the ray SC observed after two reflections, and SG observed by direct rays parallel to SC, is nothing: the great circle KO, therefore, which passes through O and F, will be the fixed or primitive secondary to which the inclination of the fixed plane of reflection at the speculum B is referred.

The demonstration of the construction will consist of two parts. It must be first shewn, that the conditions or data of the problem are observed in the construction. 2dly, That the magnitude of the arc ED, which measures the angle subtended by the observed objects is limited or determined by them.

Supposing the angle TCS to be of any unknown quantity, it has appeared, that according to the construction, the rays which come from T, and are seen after two reflections at C and B, will be observed to coincide with the rays which come

* *Supra.*

directly from S. That the conditions of the problem are fulfilled in the construction is demonstrated thus :

1st, The inclination of the reflectors B and C to the plane of motion was constructed of the magnitude which is measured by the arc KF. KC is perpendicular to the plane of motion. CF is perpendicular to the reflector C, and the inclination of these two lines CK, CF, is measured by the arc KF; but the inclination of any two planes is the same as the inclination of two lines which are perpendicular to them; the inclination therefore of the reflector C to the plane of motion is measured by the arc KF, and the speculum B is equally inclined to the plane of motion with C by the construction, the perpendiculars CF and CI being parallel when both are situated in the plane of the same great circle DBQ.

2dly, KO being the secondary to which the position of the fixed plane of reflection DFB at the speculum B was referred, that given inclination will be equal to the angle OFB, which is measured by the arc XY according to the construction, FY being a quadrant.

3dly, Moreover, FD = FB, was constructed equal to the constant angle of incidence at the fixed speculum; CBR is the angle of incidence at the fixed speculum B, and it is equal to the angle BCF, because CF and BR are parallel by construction, and CB falls on them; FB, or its equal FD therefore is truly constructed the measure of the given constant angle of incidence at the fixed speculum B.

4thly, Because it has been shewn that CO is the position of the radius CP, when the reflectors are parallel, the arc OP is rightly constructed the measure of the angular distance of the radius CP from that position.

It remains only to demonstrate that these four given quantities, KF, OP, XY, and DF, limit the magnitude of the arc

ED ::

ED: through I and F draw the arc IF: then the given arc KF or KI, and the angle IKF, measured by the given arc PO, define the triangle IKF, and in it, therefore, the side IF and the angle IFK are determined. If from IFK, the given angle DFK, measured by the arc XY, be subtracted, the remainder IFD, and IFB its supplement to 180° will be defined: the given arc FB, with the angle IFB and the arc IF, determine the angle IBF, and the arc IB, or its double BE: and the given arc BD, the arc BE, with the contained angle DBE before determined, define the arc ED, which is therefore the true measure of the angle subtended by the objects observed under the conditions fulfilled in the construction.

7. The computation of the observed angle DCE being for the present omitted, some consequences which follow from the construction may be inserted in this place, being either corollaries, or such truths as admit of easy geometrical deduction from the general proposition. The line DC will always be the position of the visual ray or line of collimation of the telescope used in the observation, and the inclination of it to the plane of motion will be measured by the complement of the arc DK to a quadrant. The line BC will be the position of the ray which passes between the reflectors B and C, and the inclination of it to the plane of motion will be measured by the complement of the arc BK to a quadrant. These arcs are left out of the figure, that the more material parts of the construction might not be confused by them.

8. Every thing else remaining, let the parallel FIM (fig. 3.) be projected on the plane of motion QOP. Through the points F and I draw the arc of a great circle NIFR. The observed* objects T and S, or, which is the same thing, the points of intersection at the sphere's surface E and D will be at equal

* Compare fig. 2.

perpendicular distances from this arc, which may be demonstrated thus. Through the points E, D, and B, draw the arcs EN, DL, and BR, perpendicular to NIFR: then the triangles DFL, FBR, being equal, DL will be equal to BR; moreover, the triangles ENI, IRB, being equal, the arcs EN, RB, will be equal: from whence it follows, that $EN = DL$, or the perpendicular distances of the points E and D from the arc of a great circle which passes through the points I and F, are equal. It appears also, from the same construction, that the arc NL, intercepted between the two perpendiculars EN, DL, is equal to twice IF: for because the triangles EIN, RIB, are equal, as are the triangles DLF, RFB, it follows, that NI is equal to IR, and LF to FR, wherefore $2IR = NR$, and $2RF = LR$: whence, by subtracting equals from equals, $2RI - 2RF = NR - LR$, or $2IF = NL$, which was the equality to be demonstrated.

9. From this last construction and demonstration the following proportion is inferred. As radius : cosine of DL or EN, so is the sine of IF to the sine of half the arc ED, or of half the observed angle: for if the arcs NE, LD (fig. 3.), be continued until they meet in the pole H, the arcs NH, LH, will be quadrants, and the triangle EHD isosceles, which, from a property of spherics too obvious to need demonstrating, gives this proportion: as the chord of NL to the chord of ED, so is radius to the sine of DH, or cosine of DL; but the chord of NL is equal to the chord of 2IF from art. 8. We have, therefore, as radius : cosine DL, so is the chord of 2FI to the chord of ED, or, which is the same proportion, as radius : cosine DL, so is the sine of IF to the sine of half ED.

10. From the last article it appears, that the sine of half the angle between the observed objects, or the sine of half ED,

is proportional to the sine of FI and the cosine of DL jointly; consequently the sine of FI being the same, $\sin. \frac{1}{2} ED$ is proportional to the cosine of DL; this will lead to the reason why in enumerating (art. 4.) the * conditions which limit the magnitude of the observed arc ED, the position of the secondary KP, in respect of the point of intersection Q and of the fixed secondary KO, was annexed: for it will appear, that every thing else being the same, the magnitude of the arc ED will depend on the position of the secondary KP, whether it be on one side of the fixed secondary KO, or on the other, the angles PKO, ρKO , being equal. Having set off $O\rho = OP$ draw the secondary $K\rho$ intersecting the parallel FIMU in the point U; and through B and U draw the arc of a great circle BUW; take $UW = BU$; and through D and W draw the arc of a great circle DW: then by the construction and demonstration in art. 6. the angle subtended by the observed objects will be measured by the arc DW, and it will be easy to shew, that DW is not equal to DE, except in two extreme cases; that is, when the fixed plane of reflection DFB is either coincident with the primitive secondary KO or perpendicular to it. Through the points F and U draw the arc of a great circle VFU, and from D draw the arc DV perpendicular to VFU: since † the sines of half the arcs DE, DW, are in a proportion compounded of the proportions of the sine of IF to the sine of FU, and of the cosine of DL to the cosine of DV, the sines of IF, FU, being equal by the construction, the sines of half the arcs ED, DW, will be in the same proportion with the cosines of DL and DV, which are evidently unequal; consequently, the sines of half the arcs DE, DW, and therefore the arcs themselves, must be unequal.

11. The angles PKO, $OK\rho$, remaining equal, when the fixed plane of reflection BFD (fig. 4.) is coincident with the

* Compare fig. 2.

† Supra.

secondary KO, or at right angles to it, the perpendiculars DL, DV, become equal in both cases, which is obvious from the equality of the triangles DVF, DLF; it follows, therefore, (art. 10.) that the sines of FI and FU, and the cosines of DL, DV, being equal, the arcs DE, DW, will be equal in these two extreme cases, but in no other.

12. Since the angle subtended by the observed objects (art. 10.) depends only on the sine of IF and the cosine of DL, it is plain, that if the points D and B be interchanged, (fig. 2, 3, 4.) the angle observed will not be altered, every thing else remaining the same; because neither the sine of IF, nor the cosine of DL, is affected by this change. For this reason in any construction for measuring angles by two reflections, the position of the * visual ray may be altered into that of the ray BC passing between the reflectors, which will become in that case the situation of the visual ray, this alteration noways affecting the observed angles.

13. While the perpendicular CI (fig. 2. and 5.) describes the parallel FIM, the angle of incidence on the moveable speculum C, that is, the angle ECI or ICB, measured by the arc BI, continually increases until it arrives at a certain limit. This limit is determined by drawing through the points B and K the arc of a great circle BKM. When the perpendicular CI arrives at M, the arc BM is the greatest possible, which will therefore be the measure of the greatest angle of incidence on the moveable speculum, according to this construction, the radius CP having then described from O an arc which is the measure of the angle FKM. Now it is plain, that if the arc MB should be greater than a quadrant, there can be no vision by two reflections, when the perpendicular CI coincides with M (supposing the moveable speculum to reflect on one side only) because the angles of incidence and reflection on any speculum

* The position of the ray DC is the same with that of the ray BG parallel to it, when referred to distant objects.

must be less than 90° . If BM be less than a quadrant, an observation by two reflections may be taken when the radius CP is directed to any point in the circumference of the plane of motion. When the arc BM is greater than a quadrant, two other limits will be produced in the circumference of the plane OCP; while the radius CP is between these limits, no observation by two reflections can be taken: these limits are constructed thus (fig. 6.). BM being greater than a quadrant, with the pole B and distance BI equal to a quadrant, describe the arc of a great circle Ii intersecting the parallel FIM in the points I and i : through I and i draw the secondaries KY, KZ: while the radius CP is between Z, and Y no observation can be taken by two reflections. If BIE, BiE , be drawn equal to a semi-circle, and DE joined, then DE will be the measure of the limiting angle which can be observed by this construction, either on one side of KO or on the other; and because, by the principles of trigonometry, the arcs BD and DE are in the same great circle, BDE being a semi-circle, we shall derive from the construction this conclusion: the difference between 180° and double the angle of incidence on the fixed speculum, will be a limit which terminates the angle observed by two reflections in every case, when the arc BM is greater than a quadrant*.

14. In any given example formed on the principles which have been demonstrated (fig. 2.) for the estimation of angles by two reflections, three of the four quantities necessary to determine the result must constantly be the same, while the fourth, that is, the arc OP, varies with the magnitude of the angle subtended by the objects observed: the different magnitudes of these three given quantities will cause a great variety of properties in constructions which depend on the general

* This termination of the angle which can be observed by two reflections may happen while the observed angle is increasing or decreasing during the revolution of the index in the plane of motion.

theory. If the angle DFK (fig. 2.), being the inclination of the fixed plane of reflection to the primitive secondary be $= 90^\circ$, and the arc KF, or the inclination of the reflectors to the plane of motion, be $= 90^\circ$ also, the construction will become that of HADLEY'S instrument (fig. 7.), whatever be the magnitude of the arc DF, that is, of the angle of incidence on the fixed speculum B: in this case the points F and O, and the points I and P, coincide. Here IF or PO measures the inclination of the reflectors to each other; and because $BF = FD$, and $BI = IE$, by construction, it follows, that $DE = 2PO$, that is, the angle subtended by the observed objects is double to the angle at which the reflectors are inclined to each other. This is a known property of HADLEY'S instrument, in which the visual ray, and the ray intermediate between the reflectors, are in the plane of motion, which is also expressed in the construction, DC and BC coinciding with the plane POC.

15. Bisect KO in F; then will $KF = 45^\circ$ (fig. 8.). The visual ray CD being coincident with the plane of motion, let the inclination of the reflectors to that plane be equal to 45° : moreover, let the angle * DFK $= 180^\circ$; so shall D coincide with O, and B with K: this will afford a good example to the general theory. Let the radius CP move into any given position, carrying with it the speculum C and its perpendicular CI: here the observed object E and the point B are always equi-distant from I; and because BI is half a quadrant by construction, it follows, that IE will be of the same magnitude, BE therefore will be a quadrant, and consequently E will coincide with P, being always in the plane of motion. The following properties are also derived from this construction. 1st, The arc DE subtended by the observed objects is equal to the arc described by the index or moveable radius CP from O;

* Compare fig. 2.

differing in this from Mr. HADLEY'S construction, in which the angle observed is equal to double the angle described by the moveable radius from the initial point of the arc O. While therefore the moveable speculum C is carried round by the radius CP in the plane of motion according to the new construction just described, the image of E moves with an angular velocity just equal to that of the radius, the motion of the image being, according to Mr. HADLEY'S invention, always greater than that of the radius in the proportion of 2 to 1. 2dly, The angles of incidence and reflection on both surfaces are constantly the same, being equal to 45° . 3dly, BI (art. 13.) being always less than 90° , observations by two reflections may be taken all round the circle, that is, angles of any magnitude may be measured by this construction. It will not be difficult in practice to regulate the inclination of the plane reflectors to the plane of motion, with the other given quantities to their true magnitude. Let the reflectors B and C be brought parallel when the index or radius CP is directed to O, being the initial point of the arc OP: in order to examine whether the fixed plane of reflection BFD be coincident with the primitive secondary KO, it is only necessary to observe the angle subtended by two given objects when the index CP is on the different sides of the initial point O: if the index be directed to unequal distances from that point at the times of observation, a correction is required (art. 11.). To examine whether the inclination of the reflectors to the plane of motion be exactly 45° , let the index CP be directed to 180° : if the inclination of the reflectors to each other be not then $= 90^\circ$, a correction must be applied. It will be known whether the inclination of the reflectors to each other be $= 90^\circ$, by observing the two opposite horizons at sea, and at land by various obvious methods. These examinations are

are wholly independent of the inclination of the telescope to the plane of motion, which is regulated to its true situation parallel to the plane OPA, by making the plane OPA fixed in regard to distant objects, and by observing if the images of objects E, seen after two reflections of the rays, describe the arc of a great circle while C is carried round the plane of motion. Any three fixed objects, at a sufficient distance, and situated in the same plane with the observer's eye, will be sufficient for making this adjustment.

Fig. 9. 10. and 11. represent the progress of the rays, and the position of the reflectors according to this construction. TC is a ray issuing from any object T in a direction parallel to the plane of the motion, and impinging on the speculum C, which is inclined to that plane at an angle of 45° : from hence it is reflected in the direction CB perpendicular to the plane OCA, and being there reflected by the speculum B proceeds in the given or constant direction BG parallel to the plane of motion OPA.

16. There is another construction which follows from the general theory, the description of which should not be omitted. This will require some little explanation. As before (fig. 12.) let OPA represent the plane of motion, K its pole, FIM a parallel or lesser circle projected on it, the distance of this parallel from the pole K being measured by the arc FK; let KO be the primitive secondary, and BFD the fixed plane of reflection on the speculum B coincident with it. The other parts of the construction * remaining, it has been demonstrated (art. 10.), that the sine of half the observed angle, that is, the sine of half ED, is proportional to the sine of IF, and the cosine of DL jointly. Every thing else being the same, it is manifest, that the sine of half ED will be proportional to the sine of IF: as therefore the arc KF, that is, the inclination of the reflecting planes to the plane of motion, is decreased,

* Compare fig. 2. and 3.

the angle measured or arc ED will become smaller at the same time, because FI decreases with KF, the angle IKF remaining. This property seems applicable to good purpose in measuring small angles, not only from the great extent of scale, which is here obtained, but from various advantageous circumstances, which will appear in the subsequent article, and from the computations annexed in those which follow.

In this construction the fixed plane of reflection is made coincident with the primitive secondary for various reasons: there are only two positions of that fixed plane which admit of easy and exact adjustments; these are when the fixed plane of reflection is either perpendicular (art. 11.) to the primitive secondary or coincident with it. The latter position is preferred exclusive of the advantages it possesses in common with the other, because it affords means for a very precise adjustment of the inclination of the reflecting planes to the plane of motion, that is, of the arc KF; for if the primitive secondary OKMD (fig. 12.) be produced, and in it DG be taken equal to four times KF, it is manifest, that when the perpendicular CI coincides with M, or, which is the same thing, when the radius CP is directed to 180° , the object E observed by two reflections will coincide with G, because $BF = FD$ and $BM = MG$ by construction. If then two given objects be observed when the index points to 180° , the inclination of the plane reflectors to the plane of motion will be one fourth part of the angle subtended by these objects.

Concerning the magnitude of the arc FB, being the measure of the angle of incidence on the fixed speculum, and of $KF =$ the inclination of the reflectors to the plane of motion, it will appear, by the computations*, that the smaller they are both taken, every thing else being the same, the more exact will be the result of the observation; but both are limited by circumstances which

* *Infra,*

should

should next be described; these will be more obvious if an outline be annexed, representing this particular case of the theory adapted to the mensuration of small angles when reduced to practice. OAPC (fig. 13.) is the plane of motion, C the moveable speculum carried round in the plane of motion by the radius CP; a ray coming from any distant object T impinges on the speculum C, and being reflected in the direction CB, is there again reflected in the direction BG, passing along the axis of a telescope. A ray coming from another distant object S, inclined to the ray TC at a small angle enters the telescope parallel to the direction of its axis, which is coincident with BG, and consequently the images of the two objects S and T will be seen to coincide in the middle of the field of the telescope, the angle subtended by them being BGT, which must be determined by the subsequent computations.

17. By this figure (fig. 13.), without further argument, it is plain, that the magnitude of the reflecting speculum C limits the constant angle of incidence on B; for were that angle = 0, the lines CB, BG, would coincide, by which means the ray BG and others adjacent to it would be intercepted from entering the telescope. The magnitude of the reflecting plane depends on the quantity of light required; if a circle of about 1 2 inches diameter be sufficient, and the perpendicular distance of the reflecting planes be made equal to five inches, the least angle of incidence, consistent with these conditions, will be about 7°. It is however to be remembered, that the magnitude of the reflectors should be adapted to the aperture of the telescope used in the observation. As the area of the speculum increases, the light admitted into the same telescope decreases, and these areas should be so proportioned as to afford equal quantities of light, so that the objects seen by two reflections, and by direct rays, may be nearly of equal brightness; but for the

fake of constructing an example to this theory, the magnitude of the reflecting planes and the angle of incidence on the fixed speculum B depending on it may be assumed of the value mentioned in this article.

18. The magnitude of the arc KF, or of the inclination of the reflecting planes to the plane of motion is limited by the angles which the observed objects subtend (art. 16.). Fig. 12. Because the greatest angle observable will be measured by four times the arc KF, it follows, that the arc KF must not be less than one fourth part of the greatest angle intended to be observed by this construction; if the inclination denoted by the arc KF be fixed at $10'$, four times that angle being $40'$ will be greater than the apparent diameters of the sun or any of the planets.

19. It remains to infer from the preceding construction (fig. 2), the actual measure of the angle subtended by the objects observed. This must be effected by computation, which will not only serve as an illustration of the theory, but afford means of estimating and comparing the errors in the angle deduced, occasioned by the unavoidable errors in observation and practical construction; an examination extremely useful in astronomical subjects: next to removing errors entirely from observations, which is scarcely to be hoped for, the lessening, circumscribing, and reducing them within known limits is an object of principal consequence.

20. The construction of fig. 2. remaining, through the points F and I (fig. 14.) draw the great circle FI. Bisect FI in Q, and through the points K and Q draw the arc KQ, which will be perpendicular to IF. To determine by computation the arc ED which measures the angle subtended by the observed objects, three spherical triangles, KQF or KIF, IFB, and DBE, must be solved, for which the data are evidently sufficient;

or the value of ED may be obtained from the solution of two triangles KQF and DFL, with the proportion demonstrated in art. 9.

21. To proceed with the computation, through D draw the arc DL perpendicular to FI, and let the sine of QKF = p , being the sine of half the arc OP, the measure of IKF: put the sine of KF = s , the sine of DF = m , the sine of DFK = n , radius = 1. In the right-angled spherical triangle KQF, the properties of spherics give this proportion: as radius to the sine of KF so is the sine of QKF to sine of QF; wherefore $\text{fin. QF} = sp$; $\text{cos. QF} = \sqrt{1 - s^2 p^2}$; and fin. FI (FI being double to QF) = $2sp \times \sqrt{1 - s^2 p^2}$. Moreover, because as rad. to cos. QK so is cos. QF to cos. KF , we have $\text{cos. KQ} = \frac{\sqrt{1 - s^2}}{\sqrt{1 - p^2 s^2}}$; and $\text{fin. KQ} = \frac{\sqrt{s^2 - s^2 p^2}}{\sqrt{1 - s^2 p^2}}$. And since as rad. : fin. QFK so is fin. KF to fin. KQ ; this proportion gives $\text{fin. QFK} = \frac{\sqrt{1 - p^2}}{\sqrt{1 - s^2 p^2}}$; and because the sine of the angle LFD is the sine of the difference (or sum) of the angles QFK, DFK, of which the sines are, $\text{fin. QFK} = \frac{\sqrt{1 - p^2}}{\sqrt{1 - s^2 p^2}}$ just found, and $\text{fin. DFK} = n$ by the data, we have from the rules of trigonometry,

$$\text{fin. * DFL} = \frac{\sqrt{1 - p^2} \times \sqrt{1 - n^2} \mp \sqrt{p^2 n^2 - n^2 s^2 p^2}}{\sqrt{1 - s^2 p^2}},$$

and since in the right-angled triangle LDF, as rad. : $\text{fin. DF} :: \text{fin. DFL} : \text{fin. DL}$, and by the problem $\text{fin. DF} = m$ it appears, that

* If the points P and Q be on different * sides of the point O as they are represented in the construction, the last term will be affected with the sign - : if P and Q be on the same side of O, the sign of the last term will be +. It may be here observed, concerning the geometrical construction (fig. 2. and 3.) that when P and Q are on different sides of O, the angle observed ED will be greater than when those points are on the same side of the initial point O, the arcs OP, Oq, being equal.

* Compare fig. 2.

$$\text{fin. DL} = \frac{\sqrt{1-p^2} \times \sqrt{m^2 - m^2 n^2} \pm \sqrt{p^2 m^2 n^2 - p^2 n^2 m^2 s^2}}{\sqrt{1-s^2 p^2}}, \text{ and}$$

$$\overline{\text{fin. DL}}^2 = \frac{m^2 - m^2 n^2 - p^2 m^2 + 2p^2 m^2 n^2 - m^2 n^2 p^2 s^2 \pm 2m^2 p n \times \sqrt{1-p^2} \times \sqrt{1-s^2} \times \sqrt{1-n^2}}{1-s^2 p^2}$$

and the square of the cosine of DL

$$\overline{\text{cof. DL}}^2 = \frac{1-s^2 p^2 - m^2 + m^2 n^2 + p^2 m^2 - 2p^2 m^2 n^2 + m^2 n^2 p^2 s^2 \pm 2m^2 p n \times \sqrt{1-p^2} \times \sqrt{1-s^2} \times \sqrt{1-n^2}}{1-s^2 p^2}$$

The sine of IF was shewn to be $2sp \times \sqrt{1-s^2 p^2}$, and its square = $4s^2 p^2 \times \overline{1-s^2 p^2}$: moreover, it was demonstrated in art. 9. that as $\text{rad.}^2 : \text{cof. DL}^2 :: \text{fin. IF}^2 : \text{fin. } \frac{1}{2} \text{ED}^2$ which gives, by substituting the values of cof. DL^2 and fin. IF^2 , and multiplying the cof. DL^2 into fin. IF^2 , $\text{fin. } \frac{1}{2} \text{ED}^2 =$

$$4s^2 p^2 \times \overline{1-s^2 p^2 - m^2 + m^2 n^2 + p^2 m^2 - 2p^2 m^2 n^2 + m^2 n^2 p^2 s^2 \pm 2m^2 p n \times \sqrt{1-s^2} \times \sqrt{1-p^2} \times \sqrt{1-n^2}}$$

and the cosine of $\frac{1}{2} \text{ED}^2 =$

$$1 - 4s^2 p^2 \times \overline{1-s^2 p^2 - m^2 + m^2 n^2 + p^2 m^2 - 2p^2 m^2 n^2 + m^2 n^2 p^2 s^2 \pm 2m^2 p n \times \sqrt{1-s^2} \times \sqrt{1-p^2} \times \sqrt{1-n^2}}$$

finally the cosine of ED is therefore =

$$1 - 8s^2 p^2 \times \overline{1-s^2 p^2 - m^2 + m^2 n^2 + p^2 m^2 - 2p^2 m^2 n^2 + m^2 n^2 p^2 s^2 \pm 2m^2 p n \times \sqrt{1-s^2} \times \sqrt{1-p^2} \times \sqrt{1-n^2}}$$

22. The particular cases inferred from the geometrical construction may be compared with this analytical value of the cosine of ED, or of the angle subtended by the observed objects. If $s=1$ and $n=1$, by substituting 1 for s and n in the expression just found, we shall have the cosine of ED = $1 - 8p^2 + 8p^4$, which is the cosine of an arc four times greater than that of which the sine = p . This answers to the properties of HADLEY'S instrument, in which KF or the inclination of the reflecting planes to the plane of motion is 90° , and its sine = $1 = s$: moreover, in HADLEY'S instrument, the fixed plane of reflection at the unmoved speculum is parallel to the plane of motion, and therefore perpendicular to any secondary of that plane; its inclination to any secondary

condary therefore will be 90° , and the sine of this inclination $= 1 = n$ by the problem. And since p is the sine of half the inclination of the reflectors, the angle of which the cosine is $1 - 8p^2 + 8p^4$ will be twice the inclination of the reflecting planes, which is a property of HADLEY'S instrument. In the analytical value of the cosine of ED, the last term is affected by two signs; these depend on the position of the secondary KP and the intersection Q in respect of the point O. If the secondary KP or the index CP be on the same side of O with the intersection Q (fig. 2.), the sign of the last term is negative: if CP and Q be on opposite sides of O, the sign of the last term will be positive; and when $DFK = 0$ or 180° , the whole term vanishes, because in that case $n = 0$. Also, if $m = 0$, $n = 1$, $s = 1$, or if $p = 1$, the last term vanishes. When $m = s = \frac{1}{\sqrt{2}}$,

$KF = 45^\circ$: in this case, if $n = 0$ the construction will be that described in art. 15. and the cosine of the observed angle ED will equal $1 - 2p^2$, the other terms vanishing: and because $1 - 2p^2$ is the cosine of an arc double to that of which the sine $= p$, it follows, that the angle observed will be equal to the arc described by the index from o , of which the sine of one half is by the problem $= p$. In every case, when $n = 0$, that is, when the fixed plane of reflection at the unmoved speculum coincides with the primitive secondary KO (fig. 2. and 12.), the cosine of $ED = 1 - 8s^2p^2 \times \frac{1 - s^2p^2 - m^2 + p^2m^2}{1 - s^2}$.

23. The sine of ED will be necessary (art. 27.) to ascertain the variation of ED from the truth occasioned by errors in the data; to obtain sin. ED let

$$1 - s^2p^2 - m^2 + n^2n^2 + p^2m^2 - 2p^2m^2n^2 + m^2n^2s^2p^2 \pm 2m^2np \times \sqrt{1 - s^2} \times \sqrt{1 - p^2} \times \sqrt{1 - n^2} = d:$$

then (art. 21.) from the value of $\text{cos. } \frac{1}{2}ED^2$ we have

$$\text{sin. } ED = 4sp \times \sqrt{d} \times \sqrt{1 - 4s^2p^2d}.$$

When s is very small, and

and $n=0$, $d=1-m^2+m^2p^2$ nearly, which gives

$$\text{fin. ED} = 4sp \times \sqrt{1-m^2+m^2p^2} \text{ nearly.}$$

24. The cosine of the observed angle represented by ED (fig. 2. and 14.) in the construction, being computed from the four given quantities p , s , m , and n , if either of these should deviate from its true value, the angle deduced will be erroneous: and from the general expression for the cosine of ED, an estimation of this error will be obtained. In the investigation, however, it must be observed, that although the small increments or decrements of arcs or sines are assumed proportional to the fluxions of these quantities, which is strictly true only in the nascent state of the increments or decrements, yet when the given variations are in a practical sense very small, the estimation of corresponding variations will be in general sufficiently exact for practical purposes.

25. Small increments and decrements, that is, small variations, being assumed proportional to the fluxions of arcs and of their sines and cosines, if the variation of the sine or cosine of any given arc be known, the cotemporary variation of the arc will be for the most part inferred from the following proportions: as $\text{fin.} : \text{rad.} :: -\overline{\text{cos.}} : \overline{\text{arc}}$; and as $\text{cos.} : \text{rad.} :: \overline{\text{fin.}} : \overline{\text{arc}}$. But these proportions must be used under restrictions very necessary to be inserted in this place, being true when applied to the intermediate parts of the quadrant only and failing at the extremities; for example, at the very beginning of the quadrant, or at the very end of the semi-circle, the variation of the cosine is the versed sine of the arcs increment or decrement, which gives the proportion as $\text{fin.} : 2 \times \text{rad.} :: -\overline{\text{cos.}} : \overline{\text{arc}}$, being wholly different from the former: in like manner, at the very extremity of the quadrant,

drant, the increment of the sine becomes the versed sine of the arcs last increment, which gives this proportion: as $\text{cof.} : 2 \times \text{rad.} :: \dot{\text{fin.}} : \dot{\text{arc.}}$. And since in this case $\dot{\text{arc}} = \text{cofine}$, we shall have, $\dot{\text{arc}} = \sqrt{2 \times \dot{\text{fin.}}}$ radius being = 1. In the other parts of the quadrant which are not very near its extremity, $\dot{\text{arc}} = \frac{\dot{\text{fin.}}}{\text{cof.}}$; having given, therefore, the variation of the sine or cosine of any arc, the sine or cosine being known, the cotemporary variation of the arc itself may be obtained, when it is either at the very extremities of the quadrant, or at some distance from those extremities. The difficulty lies in ascertaining in what part of the quadrant the value of the $\dot{\text{arc}} = \frac{\dot{\text{fin.}}}{\text{cof.}} = -\frac{\dot{\text{cof.}}}{\text{fin.}}$ begin to fail, and the value expressed by $\dot{\text{arc}} = \sqrt{2 \times \dot{\text{fin.}}}$ or $-\sqrt{2 \times \dot{\text{cof.}}}$ to take place. This leads to a general proposition comprehending both these values for the arc's variation, extended to every part of the quadrant.

The proposition is this: the difference of the cosines is to the chord of the difference of any two arcs, as the sine of an arithmetical mean between them to radius; and the difference of the sines is to the chord of the difference, as the cosine of the same arithmetical mean to radius. Let AB, AF (fig. 15.) be the given arcs; BF their difference; BL, FH, the sines; CL, CH, the cosines of the arcs AB, AF, respectively; join CA, CB, CF, and FB; FB will be the chord of the difference of the arcs AF, AB. Through B draw BG parallel to CA; then HL = BG will be the difference of the cosines, and FG the difference of the sines. Bisect FB in D, so shall DA be an arithmetical mean between the arcs FA, BA; join DC, which will intersect FB at right angles in E: through D and E draw DK, EI, perpendicular to

to CA : DK will be the sine, and CK the cosine of the mean arithmetical DA : the similar triangles CEI, CDK, FGB, give the following proportions :

HL or GB : FB :: DK : DC, and

GF : FB :: CK : DC, which was the proposition to be demonstrated*.

* When FB (fig. 15) is so small in comparison of FA, that FG shall be evanescent in comparison of FH, FH and BL will be in the ratio of equality, and consequently the ratio FH : FC equal to the ratio BL : BC, or to the ratio DK : DC ; for this reason, and because it has been proved, that as HL : FB :: DK : DC, it follows, that as HL : FB :: FH or BL : BC, that is, as the variation of the cosine is to cotemporary variation of the arc, so is the sine of the varying arc to radius ; and, for similar reasons, as the variation of the sine is to the cotemporary variation of the arc, so is the cosine to radius.

If BA be so diminished that FG shall bear a finite proportion to FH, and too great to be neglected, BL will not be either to FH or to DK in a ratio of equality : consequently, FH or BL must no longer be substituted for DK : as BA becomes less, FB being still supposed evanescent, DK approximates to the sine of $\frac{1}{2}$ FB to which it is ultimately equal when B and F are coinciding with A (fig. 16.). In which case the proportion will become as HL or HA : FB or FA :: $\frac{1}{2}$ FA : to CA, that is, as the versed sine of FA is to the arc FA so is half the arc FA to radius, or so is the arc FA to diameter.

The propositions which have been demonstrated, comprehend the variation of the arc expressed in terms of the cotemporary variation of the sine or cosine in every part of the quadrant without limitation, it being only allowed to substitute the arc FB instead of its chord, these quantities approximating the more nearly to equality as FB is smaller, and being ultimately equal in their evanescent state. Moreover, it will be easy from what has preceded to construct a plane right-lined triangle, which shall be similar to the mixtilinear triangle contained under an arc, its sine and versed sine when they are diminished sine limite. Let FA (fig. 16.) be any arc, FA the chord, FH the sine, CH the cosine of the arc FA. Bisect FA in D, join CD, and draw the right sine DK : then will the plane right-lined triangle KDC continually approximate to similarity with the mixtilinear triangle FDAH as FA becomes smaller, and the two triangles will be ultimately similar when FA is vanishing.

From these geometrical proportions, having given any arc and the variation of its sine or cosine, the cotemporary variation of the arc may be estimated by computation in general for any part of the quadrant. Let the sine of any arc be s , the cosine = c , the chord of the arc's variation = x , the given variation of the cosine = d , or the given variation of the sine = b , radius = r ; then if the cosine of the arc increases by the difference d , the chord of the cotemporary decrease of the arc, or

$$-x = \sqrt{2s^2 - 2dc} = \sqrt{2s^2 - 2dc^2 - 4d^2}$$

and if the sine of the given arc increases by the difference b

$$+x = \sqrt{2c^2 - 2bs} = \sqrt{2c^2 - 2bs^2 - 4b^2},$$

which are the mathematically true values of the chord FB, and will approximate to the magnitude of the arc FB as that arc is continually diminished. The following expressions for the chord of the variation x are more compendious, and will be sufficiently near the truth when FB is very small.

$$-x = \frac{s}{c} - \sqrt{\frac{s^2}{c^2} - \frac{2d}{c}}$$

$$+x = \frac{c}{s} - \sqrt{\frac{c^2}{s^2} - \frac{2b}{s}}$$

In these four expressions it must be observed, that the sine and cosine are supposed to vary by increase: should the variation be a decrement, the sign of x and of b or d must be changed.

26. Let the quantities p, s, m, n , vary by small increments $\dot{p}, \dot{s}, \dot{m}, \dot{n}$, respectively, then to obtain the cotemporary variation of cof. ED, because (art. 21.)

$$\text{Cof. ED} = \frac{1 - 8s^2p^2 \times \sqrt{1 - s^2p^2 - m^2 + m^2n^2 + m^2p^2 - 2p^2m^2n^2} + m^2n^2s^2p^2 \pm 2m^2np \times \sqrt{1 - p^2} \times \sqrt{1 - n^2} \times \sqrt{1 - s^2}}{1}$$

by taking the fluxion of the equation we have

$$\begin{aligned}
\text{Col. ED} = & -16s^2 p \dot{p} \times \frac{1-2s^2 p^2 - m^2 + n^2 m + 2m^2 p^2 - 2m^2 n^2 p^2 + 2n^2 m^2 s^2 p^2}{\pm \frac{m^2 n p \times \sqrt{1-n^2} \times \sqrt{1-s^2} \times 3 - 4p^2}{\sqrt{1-p^2}}} \\
& -16p^2 s \dot{s} \times \frac{1-2s^2 p^2 - m^2 + n^2 m^2 + p^2 m^2 - 2p^2 m^2 n^2 + 2p^2 m^2 n^2 s^2}{\pm \frac{m^2 n p \times \sqrt{1-n^2} \times \sqrt{1-p^2} \times 2 - 2s^2}{\sqrt{1-s^2}}} \\
& +16s^2 p^2 m \dot{m} \times \frac{1-n^2-p^2 + 2p^2 n^2 - s^2 p^2 n^2 \mp 2pn \times \sqrt{1-n^2} \times \sqrt{1-s^2} \times \sqrt{1-p^2}}{\pm \frac{m^2 n p \times \sqrt{1-n^2} \times \sqrt{1-p^2} \times p \times 1 - 2n^2}{\sqrt{1-n^2}}} \\
& +16s^2 p^2 m^2 \dot{n} \times \frac{-n + 2p^2 n - s^2 p^2 n \mp \frac{\sqrt{1-s^2} \times \sqrt{1-p^2} \times p \times 1 - 2n^2}{\sqrt{1-n^2}}}{\pm \frac{m^2 n p \times \sqrt{1-n^2} \times \sqrt{1-p^2} \times p \times 1 - 2n^2}{\sqrt{1-n^2}}}
\end{aligned}$$

27. This value of $\overline{\text{col. ED}}$ is expressed in terms of the variation of the sines of the given quantities: if it be necessary to express $\overline{\text{col. ED}}$ in terms of the variation of the arcs themselves, it must first be considered to what part of the quadrant they belong: for example, if s be a sine of an arc b not very near the extremity of the quadrant, and the variation be \dot{s} , the cotemporary variation of the arc \dot{b} will be $\frac{\dot{s}}{\sqrt{1-s^2}}$; but if the variable arc be nearly $=90^\circ$, and becomes exactly equal to it ultimately having varied by a small arc \dot{b} of which the versed sine $=v$; then will $-\dot{s}$ = the versed sine of \dot{b} and $-\dot{b} = \sqrt{2v}$. Lastly, if the variable angle approximates to 90° , but is not equal to it, and the variation of its sine should be $=\dot{s}$, the cotemporary variation of the arc must be obtained from the general theorem in art 25. When either of the two latter cases happen, the variation of the arc must be determined for each particular case; but it will be necessary to give a general expression for $\overline{\text{col. ED}}$ in terms of the variations of the given arcs, of which p, s, m, n , are the respective sines when these arcs are at some distance from 90° ; this is contained in the next article.

28. Let the angle $\overset{\circ}{\text{QKF}} = a$ (fig. 14.); the arc $\text{KF} = b$; the arc $\text{DF} = c$, and the angle $\text{DFK} = d$; their respective increments being $\overset{\circ}{a}$, $\overset{\circ}{b}$, $\overset{\circ}{c}$, and $\overset{\circ}{d}$, their fines p , s , m , and n , and the contemporary increments of their fines $\overset{\circ}{p}$, $\overset{\circ}{s}$, $\overset{\circ}{m}$, and $\overset{\circ}{n}$: from the proportion contained in art. 24. we shall have $\overset{\circ}{p} = \overset{\circ}{a} \times \sqrt{1-p^2}$, $\overset{\circ}{s} = \overset{\circ}{b} \times \sqrt{1-s^2}$, $\overset{\circ}{m} = \overset{\circ}{c} \times \sqrt{1-m^2}$, and $\overset{\circ}{n} = \overset{\circ}{d} \times \sqrt{1-n^2}$, which being substituted in the value of $\overline{\text{col. ED}}$ last found will give

$$\begin{aligned} \overline{\text{Col. ED}} = & -16s^2 \times \sqrt{1-p^2} \times p \overset{\circ}{a} \times \sqrt{1-2s^2p^2-m^2+n^2m^2+2m^2p^2-4m^2n^2p^2+2s^2m^2n^2p^2} \\ & + \frac{m^2np \times \sqrt{1-s^2} \times \sqrt{1-n^2} \times 3-4p^2}{\sqrt{1-p^2}} \\ & -16p^2 \times \sqrt{1-s^2} \times s \overset{\circ}{b} \times \sqrt{1-2s^2p^2-m^2+n^2m^2+p^2m^2-2p^2m^2n^2+2s^2m^2n^2p^2} \\ & + \frac{m^2np \times \sqrt{1-n^2} \times \sqrt{1-p^2} \times 2-3s^2}{\sqrt{1-s^2}} \\ & +16s^2p^2 \times \sqrt{1-m^2} \overset{\circ}{m} \times \sqrt{1-n^2-p^2+2p^2n^2-s^2p^2n^2} \mp 2pn \times \sqrt{1-n^2} \times \sqrt{1-s^2} \times \sqrt{1-p^2} \\ & +16s^2p^2m^2 \times \sqrt{1-n^2} \times \overset{\circ}{d} \times -n+2p^2n-s^2p^2n \mp \frac{p \times \sqrt{1-s^2} \times \sqrt{1-p^2} \times \sqrt{1-2n^2}}{\sqrt{1-n^2}}. \end{aligned}$$

This quantity (art. 23.) being divided by the sine of the observed angle, the variation of that angle or $\overline{\text{ED}}$ will be the quotient.

29. In the expression for $\overline{\text{col. ED}}$ contained in art. 26. the variations $\overset{\circ}{p}$, $\overset{\circ}{s}$, $\overset{\circ}{m}$, and $\overset{\circ}{n}$, are arbitrary, as are $\overset{\circ}{a}$, $\overset{\circ}{b}$, $\overset{\circ}{c}$, and $\overset{\circ}{d}$, in the last article. If a condition be annexed to the variation of any of them, two or more may become dependant on each other; and their relation must be determined by the nature of the case. Moreover, if one or more of the given arcs and their fines should be correct, the variations corresponding and all the terms multiplied into them will vanish. To give an example of the use of these expressions before they are applied to the immediate purpose of examining the new constructions

described in art. 15. and 16. let it be required to assign what error is occasioned in observing a given angle with a HADLEY'S sextant, in which the telescope is parallel to the plane of motion, but the two reflectors deviate from their perpendicular to that plane by a small angle \dot{b} . Suppose the error of half the arc pointed to by the index to be \dot{a} , and consequently the error of the sine of half that * arc $= \dot{a} \times \sqrt{1-p^2} = \dot{p}$: in this case, because the inclination of the reflectors to the plane of motion is nearly $= 90^\circ$, the variation of the sine will be equal to the versed sine of the small arc \dot{b} , by which the inclination deviates from 90° ; let v be the versed sine of \dot{b} , then will $-\dot{s} = v$ (s varying by a decrement of v). Moreover, because a condition is annexed, which is, that the line of observation is parallel to the plane of motion, the variations \dot{s} , \dot{m} , and \dot{n} , will be dependent on each other. To investigate their relation let $FO = \dot{b}$ (fig. 7.) be the small arc which measures the deviation of the reflectors from the perpendicular to the plane of motion: then, because sin. $DO = m$, and sin. $DOF = n = 1$ by the problem, when F from having been coincident with O has moved through the arc OF , it is plain, that $\dot{n} = \text{fin. DFO} - \text{fin. DOF} = (\dot{n}$ being a decrement); but, by the † properties of spherics, $\text{cof. DFO} = \frac{\sqrt{2v} \times \text{cof. DF}}{\text{fin. DF}} = \frac{\sqrt{2v} \times \sqrt{1-m^2}}{m}$: and FO being very small, the

* p here, as in the general solution, denotes the sine of half the arc to which the index on the plane of motion is directed, that is, $p =$ the sine of one-fourth of the angle observed in Mr. HADLEY'S construction.

† Fig. 7. as rad.: $\text{cotang. DF} :: \text{tang. FO} : \text{cof. DFO}$, that is, FO being very small, and therefore $\overline{FO}^2 = 2 \times$ versed sine of FO , as rad.: $\text{cotang. DF} :: \sqrt{2v} : \text{cof. DFO}$: by the problem sin. $DF = m$, and $\text{cof. DF} = \sqrt{1-m^2}$, wherefore $\text{cot. DF} = \frac{\sqrt{1-m^2}}{m}$, which gives $\text{cof. DFO} = \sqrt{2v} \times \frac{\sqrt{1-m^2}}{m}$.

fine of DFO = $1 - \frac{v \times \sqrt{1-m^2}}{m}$, from which $i = \sin.$ DOF being subtracted leaves $\dot{n} = \frac{-v \times \sqrt{1-m^2}}{m^2}$; or because $\dot{s} = -v$, $\dot{n} = \frac{+s \times \sqrt{1-m^2}}{m^2}$.

Moreover, the* quantity $\frac{1-s^2}{1-n^2}$ in the nascent state of $\sqrt{1-s^2}$ and $\sqrt{1-n^2} = \frac{m^2}{1-m^2}$: and $\sqrt{\frac{1-s^2}{1-n^2}} = \frac{m}{\sqrt{1-m^2}}$. Making therefore in the

general expression contained in art. 26. $\frac{-v \times \sqrt{1-m^2}}{m^2} = \dot{n}$, $-v = \dot{s}$,

$\dot{a} \times \sqrt{1-p^2} = \dot{p}$, and $\frac{m}{\sqrt{1-m^2}} = \sqrt{\frac{1-s^2}{1-n^2}}$, $n = s = 1$, we shall have

Coſ. ED = $-16pa \times \sqrt{1-p^2} \times \sqrt{1-2p^2} + 16p^2v \times \sqrt{1-2p^2} + p^2m^2 \mp mp \times \sqrt{1-m^2} \times \sqrt{1-p^2}$
 $+ 16p^2v \times \sqrt{1-p^2-m^2} + m^2p^2 \mp mp \times \sqrt{1-m^2} \times \sqrt{1-p^2} = -16pa \times \sqrt{1-p^2} \times \sqrt{1-2p^2} +$
 $16p^2v \times \sqrt{2-3p^2-m^2} + 2p^2m^2 \mp 2mp \times \sqrt{1-m^2} \times \sqrt{1-p^2}$: and
 because the sine of the observed angle is $4p \times \sqrt{1-p^2} \times \sqrt{1-2p^2}$,
 the error of the observation itself, that is,

$$\overline{ED} = 4\dot{a} - \frac{4pv \times \sqrt{2-3p^2-m^2} + 2p^2m^2 \mp 2mp \times \sqrt{1-m^2} \times \sqrt{1-p^2}}{\sqrt{1-p^2} \times \sqrt{1-2p^2}}$$

In this example the position of the telescope has been supposed exactly in the plane of motion; should it be inclined to that plane at a small angle, of which the versed sine = v , the position of the reflectors and the arc pointed to by the index being correct, the general value of \overline{ED} will give the error of the observation, or $\overline{ED} = \frac{-4pv \times \sqrt{1-p^2}}{1-2p^2}$ †.

30. To

* The nascent value of $\frac{1-s^2}{1-n^2} = \frac{-2s\dot{s}}{-2n\dot{n}}$; but $\dot{n} = \frac{-v \times \sqrt{1-m^2}}{m^2} = \frac{+s \times \sqrt{1-m^2}}{m^2}$.

wherefore $\frac{1-s^2}{1-n^2} = \frac{m^2}{1-m^2}$, when s and n are nearly = 1.

† When the position of the telescope only is erroneous, the points F and O coincide

30. To examine in what degree an observation taken by the new construction described in art. 15. is affected by known errors in the given quantities, let the reflectors B and C deviate by excess from their true angle of inclination to the plane of motion by a small angle $+b$: let the angle of incidence on the fixed speculum be too great by the increment c : let the fixed plane of reflection deviate from the secondary KO with which it should coincide by a small angle d ; and lastly, let the error of the arc pointed to by the index be $= 2a$; then these variations are arbitrary, no condition being annexed. Moreover, by the construction $m = s = \frac{1}{\sqrt{2}}$, and $n = 0$, which values being substituted in the general expression contained in art. 28. we shall have.

$$\text{Cof. ED} = -4ap \times \sqrt{1-p^2} - 4p^2b \times \sqrt{1-p^2} + 4p^2c \times \sqrt{1-p^2} \mp 2\sqrt{2}p^3d \times \sqrt{1-p^2};$$

and because the sine of the angle measured $= 2p \times \sqrt{1-p^2}$, the error of the observation required, or

coincide (fig. 7.) let the inclination of the telescope to the plane of motion with which it should coincide, be measured by the small arc Dd ; then the corresponding variation of the angle DOK will be DOd . Let $Dd = e$, and its versed sine $= v$; since the sine of $DO = m$, and the sine of $DOK = 1 = n$ by the problem, \dot{n} the versed sine of DOd ; but $DOd = \frac{e}{m}$, and the versed sine of $DOd = \frac{e^2}{2m^2} = \frac{v}{m^2}$:

wherefore $\dot{n} = \frac{-v}{m^2}$. This being premised, it appears from art. 26. when \dot{p} , and \dot{s} ,

are $= 0$, that $\text{cof. ED} = +16s^2p^2m^2\dot{n} \times -n + 2p^2n - s^2p^2n, \pm \frac{\sqrt{1-s^2} \times \sqrt{1-p^2} \times p \times \sqrt{1-2n^2}}{\sqrt{1-n^2}}$

$+ 16s^2p^2m\dot{m} \times \sqrt{1-n^2 - p^2} + 2p^2n^2 - s^2p^2n^2 \mp 2pn \times \sqrt{1-n^2} \times \sqrt{1-s^2} \times \sqrt{1-p^2}$
in which quantity, substituting 1 for s , 1 for n , and $\frac{-v}{m^2}$ for \dot{n} , we shall have

$\text{cof. ED} = +16p^2v \times \sqrt{1-p^2}$, which being divided by the sine of the observed angle $= 4p \times \sqrt{1-p^2} \times \sqrt{1-p^2}$, the quotient will be the variation of that angle or $\text{ED} = \frac{-4vp \times \sqrt{1-p^2}}{1-2p^2}$.

ED =

$$\overline{\dot{E}D} = 2\dot{a} + 2p\dot{b} \times \sqrt{1-p^2} - 2p\dot{c} \times \sqrt{1-p^2} \pm \sqrt{2p^2\dot{d}}$$

It appears from the first term $2\dot{a}$, that an error in the arc pointed to by the index, causes an equal error in the observed angle; whereas a double error is caused by it in HADLEY'S sextant, which gives the new construction considerable advantages: to counter-balance these the errors in HADLEY'S construction, caused by a wrong position of the reflecting planes, &c. are almost evanescent; whereas the three last terms in the value of $\overline{\dot{E}D}$ just found, may become considerable, unless great care be taken in making the adjustments: the separation also of the images, when in contact, caused by any unsteadiness of the instrument will be greater than in Mr. HADLEY'S construction*; but

* The variation of the observed angle $\overline{\dot{E}D}$ will shew how much the images, seen in contact in the field of the telescope will appear to divaricate on any motion of the entire construction. For example, while the images of the observed objects are coincident in the field of the telescope, suppose that Mr. HADLEY'S instrument were turned round in its own plane through a small angle: here s , n , and p , not being affected by this motion, it follows, that \dot{s} , \dot{n} , and $\dot{p} = 0$, $m =$ the sine of the angle of incidence on the fixed speculum, being the only quantity which suffers alteration: let its variation $= \dot{m}$, which will give from art. 26. the corresponding variation in the cosine of the observed angle, or

$$\text{Cof. } \overline{\dot{E}D} = +16s^2 p^2 m \dot{m} \times \sqrt{1-n^2-p^2} + 2p^2 n^2 - s^2 p^2 n^2 \mp 2pn \times \sqrt{1-n^2} \times \sqrt{1-s^2} \times \sqrt{1-p^2} \\ = 0, \text{ because } n=s=1. \text{ Wherefore any motion of the images in the plane of the instrument will not cause the least separation of them. Now suppose the whole to be turned on an axis situated in the plane of motion, and perpendicular to the telescope's axis: if the angular motion be measured by an arc of which the versed sine } = v, \text{ the points in contact will be separated through an angle } = \frac{4vp \times \sqrt{1-p^2}}{1-2p^2},$$

p being the sine of one quarter of the angle observed; but the quantity v being very small, when the angular motion does not exceed $30'$, the divarication of the images will be inconsiderable. All oblique motions of the telescope's axis, and consequently of the image seen by direct rays, may be resolved into those that have

but in measuring the smaller angles, this separation of the images, as well as the errors expressed by the three last terms will be greatly diminished while that which is denoted by $2\dot{a}$ contained in the first term is not increased. On the whole, from the properties which have been demonstrated to belong to this construction described in art. 15. it may seem worthy of attention in practice, for some astronomical as well as other uses.

31. By the same way of examination it may be judged, whether the method of observing by two reflections from plane surfaces be applicable to the mensuration of small angles, according to the construction described in art. 16. Let the errors of the four given quantities (as in the last article) be $2\dot{a}$ = the error of the arc

have been considered, which are perpendicular to each other: and from hence the reason appears, why the motion of a ship at sea does not much disturb the observation of angles by Mr. HADLEY'S instrument.

The new construction described in art. 15. is not so well adapted for observation where it cannot be steadily fixed. When the images are in contact, if the instrument be turned in its own plane through a small angle e'' the separation of the images will be $= 2e''p^2$ (because $d'' = \sqrt{2}e''$, vid. p. 426.) p signifying the sine of half the observed angle: this it is evident will most affect the observation of the larger angles; but in measuring those that are small, the divarication will become inconsiderable. Moreover, if the angular motion of the instrument be e'' , when it turns round an axis in the plane of motion, and perpendicular to the telescope's axis, the separation of the images will be $= 2e''p \times \sqrt{1-p^2}$, p. 426. which it is plain will most disturb the observations of angles about 90° , but will scarcely alter the contact of the images, when the angles measured are very small, or near 180° .

The objects observed and their images are here understood to be physical points: thus, when the two images of the sun are seen by direct and reflected rays, and the limbs appear precisely in contact, if by any motion of the instrument the contact is disturbed, the points which before touched, being the observed objects, are said to be separated, whether the centres of the solar images approach or recede from each other, the separation being estimated in the direction of an arc which passes through the centers of the two solar images.

Experience must determine in what degree this separation of the images will disturb observations taken at sea with the new construction.

pointed to by the index; \dot{b} = the error of the inclination of the reflectors to the plane of motion; \dot{c} = the error in the angle of incidence on the fixed speculum; and \dot{d} = the inclination of the fixed plane of reflection to the primitive secondary with which it should coincide. Referring to the general value of $\overline{\text{col. ED}}$, (art. 28.) and making $n = 0$ we shall have

$$\overline{\text{Col. ED}} = -16s \times \sqrt{1-p^2} p s^2 \times \sqrt{1-2s^2 p^2 - m^2 + 2m^2 p^2} - 16p^2 s i \times \sqrt{1-s^2} \times \sqrt{1-2p^2 s^2 - m^2 + m^2 p^2} + 16s^2 p^2 \dot{c} m \times \sqrt{1-p^2} \times \sqrt{1-p^2} \mp 16m^2 p^3 s^2 \dot{d} \times \sqrt{1-s^2} \times \sqrt{1-p^2},$$

and because s being very small, the sine of ED (art. 23.) approximates to $4sp \times \sqrt{1-m^2+p^2 m^2}$, the error of the observation itself, or $\overline{\text{ED}} =$

$$\frac{4as \times \sqrt{1-p^2} \times \sqrt{1-2p^2 s^2 - m^2 + 2p^2 m^2}}{\sqrt{1-m^2+p^2 m^2}} + \frac{4pb \times \sqrt{1-s^2} \times \sqrt{1-2p^2 s^2 - m^2 + m^2 p^2}}{\sqrt{1-m^2+p^2 m^2}} - \frac{4spmc \times \sqrt{1-m^2} \times \sqrt{1-p^2}}{\sqrt{1-m^2+p^2 m^2}} \pm \frac{4m^2 p^2 s \dot{d} \times \sqrt{1-s^2} \times \sqrt{1-p^2}}{\sqrt{1-m^2+p^2 m^2}}.$$

The first term of this expression gives the relation between any small variation in the arc pointed to by the index, and the corresponding alteration in the angle observed; if therefore the variation on the divided arc be any small angle $\pm 2\dot{a}$, + or - the first term will express the variation by which the observed angle is increased or diminished. According to the magnitude of m and s assumed for this construction m being the sine of 7° , and $s =$ the sine of $10'$, it appears, that at the very beginning of the scale one second of a degree in the angle observed corresponds to somewhat less than three minutes on the divided arc OP; that is, when $2\dot{a} =$ about $173''$, $\overline{\text{ED}} = 1''$,

\dot{c} , \dot{b} , and \dot{d} , not being here considered. When $p = \frac{1}{2}$, the index then pointing to 60° , one second in the observed angle cor-

responds to about $199''$ in the divided arc OP : when p is nearly $= 1$, the index being then directed to almost 180° , it must describe above 2 degrees to make an alteration of $1''$ in the observed angle. The second term expresses the variation in the observation occasioned by an error b in adjusting the inclination of the reflecting planes to the plane of motion; but b (art. 18.) cannot exceed $\frac{1}{4}$ of the least angle visible in the telescope, consequently the utmost value of the second term cannot be so great as that least angle, being at its limit when $p = 1$: it is manifest when p is small, that the second term is so much diminished, as to be in a physical sense evanescent. The same may be said of the fourth term, containing the error of the optical adjustment d , which besides is multiplied into s the sine of $10'$. The third term is occasioned by the error c , for which, considerable latitude must be allowed, suppose $3'$: to estimate the effect of this error on the observation, let a case be assumed: let the index be directed to 90° when an observation is taken for determining the angle subtended between two objects: then will $p = \frac{1}{\sqrt{2}}$; by substituting $\frac{1}{\sqrt{2}}$ for p , the sine of 7° for m , the sine of $10'$ for s , and $180''$ for c in the third term, we shall have, by computation, the value of that term, or the error in the observation occasioned by this deviation of the angle of incidence from its true magnitude $= .''090$ not the tenth part of a second. This is rather an unfavourable case, the variation being not much less than at its maximum when $p = \frac{1}{\sqrt{2}}$: if p is small, or nearly $= 1$, the * variation will be wholly insensible.

32.

* The variation is a maximum when $p =$ the sine of $35^\circ 12'$; and consequently the arc pointed to by the index $= 70^\circ 24'$. Substituting therefore the sine of $35^\circ 12'$ for

32. From contemplating the value of the error = \overline{ED} , as expressed by the four terms just referred to, some further observations are suggested. It appears, that setting aside the error of the scale expressed by the first term (the angles measured being here supposed less than $22' 56'' 33'''$) all the others become smaller as the quantity p , and consequently the angle measured is diminished, p being multiplied into each of the three last terms. This is a material circumstance: for the same given error would affect the mensuration of the smaller angles in a greater proportion than the larger. Moreover, if $p = 1$, or approximates to that quantity, the index then pointing to an angle nearly = to 180° , the first term and the two last terms become almost evanescent, not only from the circumstances that have been considered, but from the quantities $1 - p^2$, $\sqrt{1 - p^2}$, which are multiplied into them. This also the observer may avail himself of: for supposing he should know, that the angle of incidence on the fixed speculum, and the fixed plane of reflection, are imperfectly adjusted, and even that the divided arc is incorrect, he may almost wholly avoid the errors which they would occasion, by so adjusting the inclination of the reflectors to the plane of motion, in respect of the angle measured, that for p in the third term, (p. 429.) every thing else remaining, the maximum of variation in the observed angle on account of $3'$ difference in the angle of incidence on the fixed speculum will appear to be = $'' .098$.

The error of an observation occasioned by a variation \dot{c} in the angle of incidence on the fixed speculum, can never exceed the $\frac{1}{1137}$ part of \dot{c} , which is the maximum of error, the angle measured being = $22' 56'' 33'''$, the index then pointing to $70^\circ 24'$. The error, caused by a small angle \dot{d} , at which the fixed plane of reflection is inclined to the primitive secondary with which it should coincide, cannot exceed the $\frac{1}{1198}$ part of \dot{d} , which is its maximum when the angle measured is $32' 33'' 3'''$, the index then being directed to $109^\circ 20'$.

the index shall point to some degree near to 180°, which is done by making that inclination very little more than one-fourth of the angle to be observed.

33. The tables I. and II. are calculated for taking the diameters of the sun and planets: the construction being formed on the principles which have been explained (art. 16. 17. 18. 31. 32. fig. 12. 13.) The fixed plane of reflection is coincident with the primitive secondary, and consequently $n = 0$: the common inclination of the reflectors to the plane of motion = 10'; and the constant angle of incidence on the fixed speculum = 7°.

T A B L E I.

Arc pointed to by the index.	Observed angle.	Diff.
1°	0 20 47	20 47
2°	0 41 34	20 47
3°	1 2 21	20 47
4°	1 23 8	20 46
5°	1 43 54	20 46
6°	2 4 40	20 45
7°	2 25 25	20 45
8°	2 46 10	20 44
9°	3 6 54	20 43
10°	3 27 37	

T A B L E II.

Arc pointed to by the index.	Observed angle.			Diff.	
	'	"	'''	"	'''
100°	30	32	51	13	28
101°	30	46	19	13	20
102°	30	59	39	13	12
103°	31	12	51	13	3
104°	31	25	54	12	54
105°	31	38	48	12	46
106°	31	51	34	12	37
107°	32	4	11	12	28
108°	32	16	39	12	19
109°	32	28	58	12	11
110°	32	41	9		

The divarication of the images while they traverse the field of the telescope during the time of an observation, and the errors of the observed angle in consequence of any change in the quantities m * and n (p. 429) should they appear to be of sensible magnitude, may be diminished until they are in physical sense evanescent, by altering the values of s and m (art. 31.): for this purpose it will be requisite to use two separate constructions; the one for observing very small angles, those, for example, which do not exceed $2'$: and the other, for measuring such angles as are subtended by the sun and moon. In the former of these s may be assumed = the sine of $30''$, $m = \sin. 7^\circ$, and $n = 0$. From these data tab. III. is calculated. In the other construction, because very small reflecting surfaces are necessary to observe the sun by two reflections (art. 17.) m may be assumed = $\sin. 1^\circ$, s being = $\sin. 10'$, and $n = 0$: from which conditions the fourth table is calculated. These tables may be easily extended, by calculating from the value of $\cos. ED$ or $\overline{\sin. \frac{1}{2}ED^2}$ contained in art. 21. or 22.

* Let the telescope with the entire construction be steadily fixed: then if the objects observed be in contact while the touching points occupy the center of the field, the angle of incidence on the fixed speculum will be of its true magnitude; that is, its sine or m will = $\sin. 7^\circ$ in tables I. II. and III.; and $m = \sin. 1^\circ$ in table IV. The fixed plane of reflection also will be coincident with the primitive secondary in all the constructions corresponding to tables I. II. III. and IV. The telescope continuing unmoved, the diurnal motion of the heavens will cause the points in contact to leave the center of the field; this will occasion no alteration in the quantities s and p , but will affect m and n only: therefore, \dot{s} and $\dot{p} = 0$. To estimate the effects of this change in the values of m and n , let $\dot{m} = \dot{c} \times \sqrt{1 - m^2}$, and $\dot{n} = \dot{c} \times \sqrt{1 - n^2}$, as in art. 28. and suppose a line to be drawn through the centre of the field in a plane, perpendicular to the plane of motion: this line will be in the fixed plane of reflection; and any deviation of the points in contact through a small angular space \dot{c} , from the center of the field will cause an equal variation \dot{c} in the

the

the angle of incidence on the fixed speculum; the corresponding separation of the images will be $= \frac{4spmc \times \sqrt{1-n^2} \times \sqrt{1-p^2}}{\sqrt{1-m^2+m^2p^2}}$ (p. 429.) which is the greatest possible

when $p = \sqrt{\frac{\sqrt{9-10m^2+m^4}-3-3m^2}{4m^2}} = \text{fine of } 35^\circ 11' 47''$ (if $m = \text{fin. } 7^\circ$,

and $s = \text{fin. } 10'$, as in tab. I. and II.) being then $= \frac{c}{1837}$; but if $s = \text{fin. } 30''$, as in

tab. III. the greatest separation will be only $\frac{c}{36740}$, corresponding to less than one-

third of a degree for the images motion through $10'$ in the field of the telescope.

In like manner let a line be drawn through the center of the field perpendicular to the line before described; any deviation of the points in contact through a small angle

e in the direction of this line will cause the plane of reflection at the fixed speculum to be inclined to the primitive secondary with which it should coincide at an angle $=$

$\frac{e}{m}$; this will occasion a separation of the images $= \frac{4mp^2se \times \sqrt{1-s^2} \times \sqrt{1-p^2}}{\sqrt{1-m^2+m^2p^2}}$

(page 429. $\frac{e}{m}$ being there substituted for d) which is the greatest possible when

$p = \sqrt{\frac{\sqrt{9-8m^2}-3-4m^2}{4m^2}}$. If $m = \text{fin. } 7^\circ$ and $s = \text{fin. } 10'$, as in tab. I. and II.

the greatest separation of the images will be $= \frac{e}{1828} = \frac{d}{14996}$; but if $s = \text{fin. } 30''$

and $m = \text{fin. } 7^\circ$, as in tab. III. it will only $= \frac{e}{36560} = \frac{d}{299920}$, which answers to

a divarication of less than $1'''$ for the images motion through $10'$ in the field of the telescope, in the direction of the line above described, which is drawn

through the center of the field, and perpendicular to the fixed plane of reflection.

It must be remembered, that the separations of the images here estimated are greater than can possibly happen in these constructions, when the index is

directed to any other points of the circumference of the plane of motion (the distance of the images from the center the field not exceeding $10'$) and are,

even in this case, physically speaking, evanescent.

Fig. I.

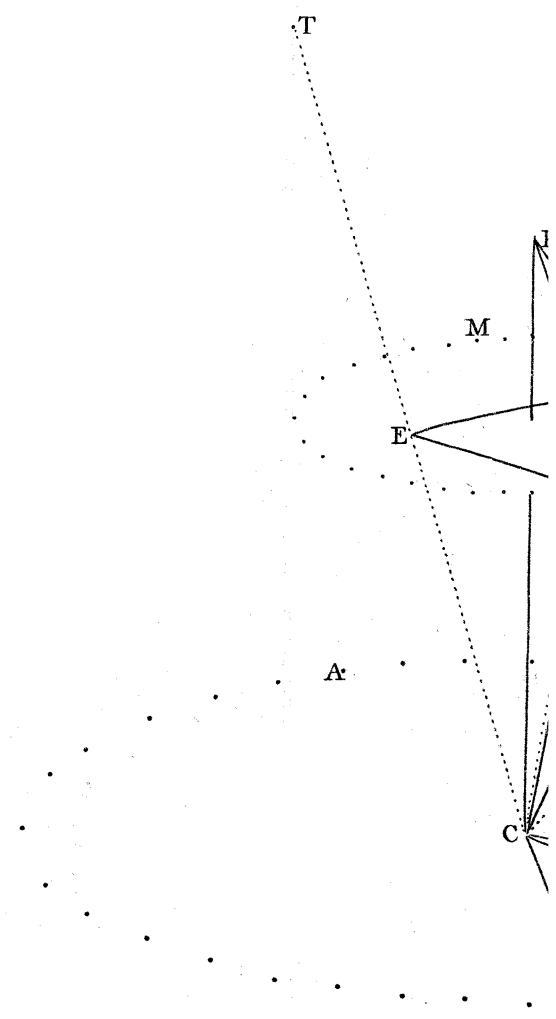
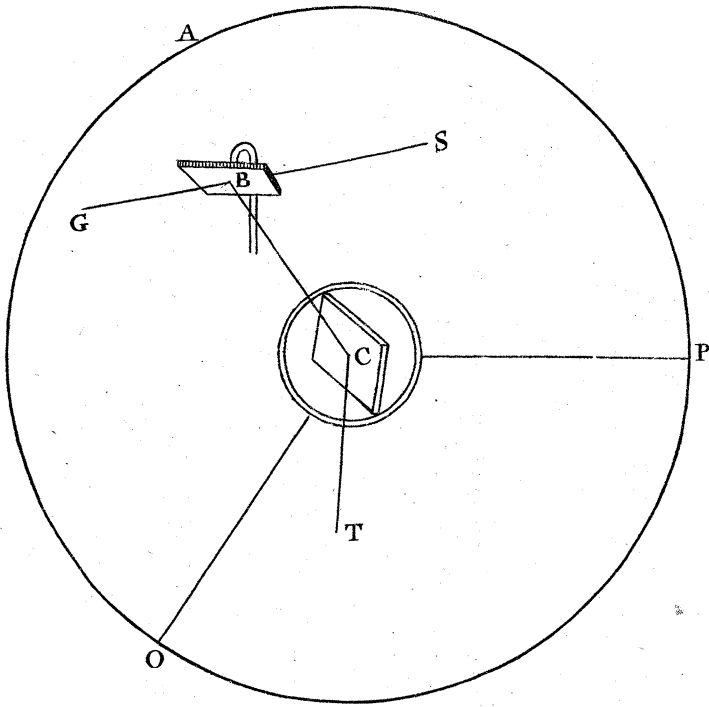

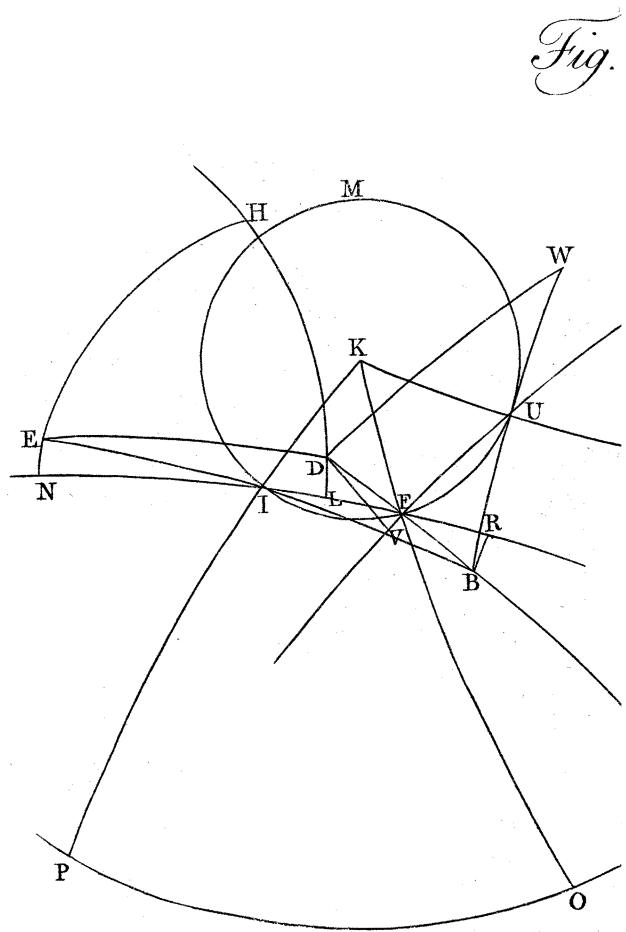
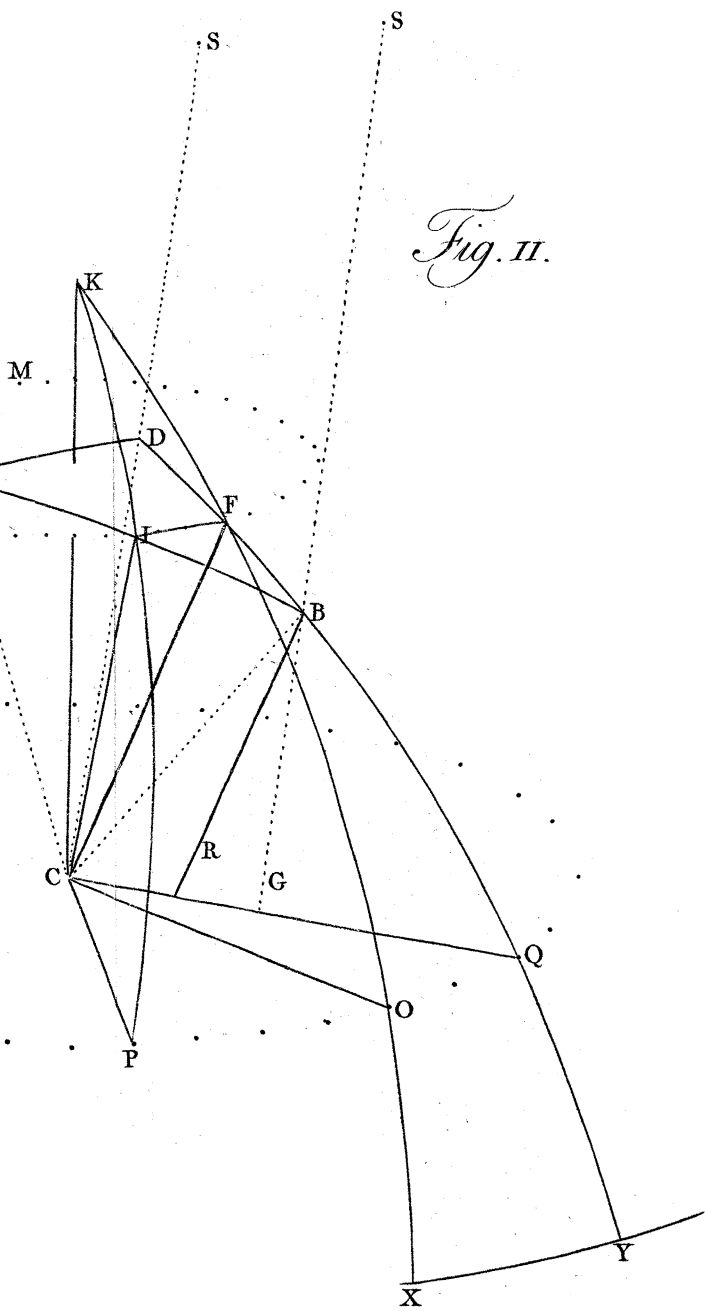

Fig. III.

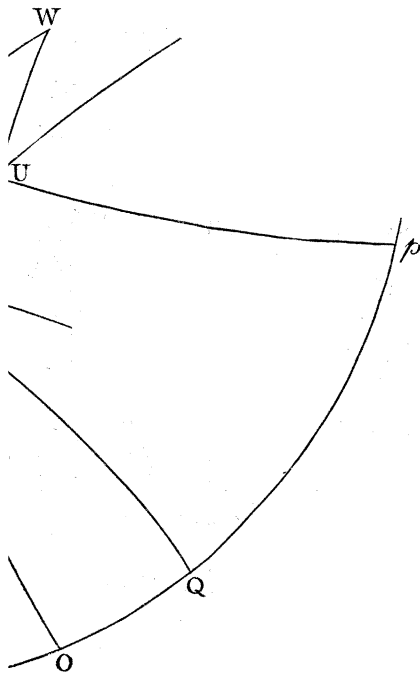

Fig. IV.

Fig. V.

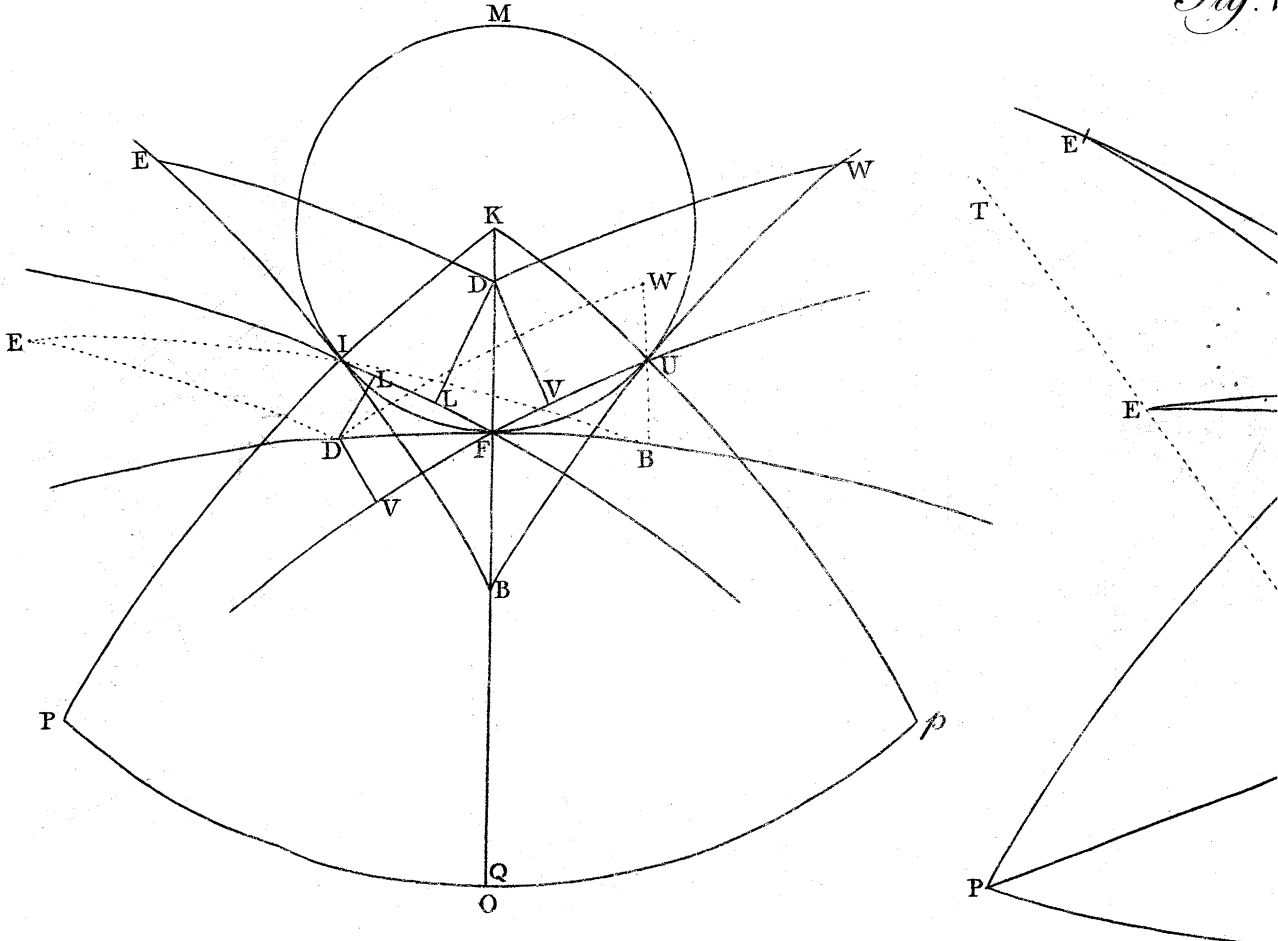
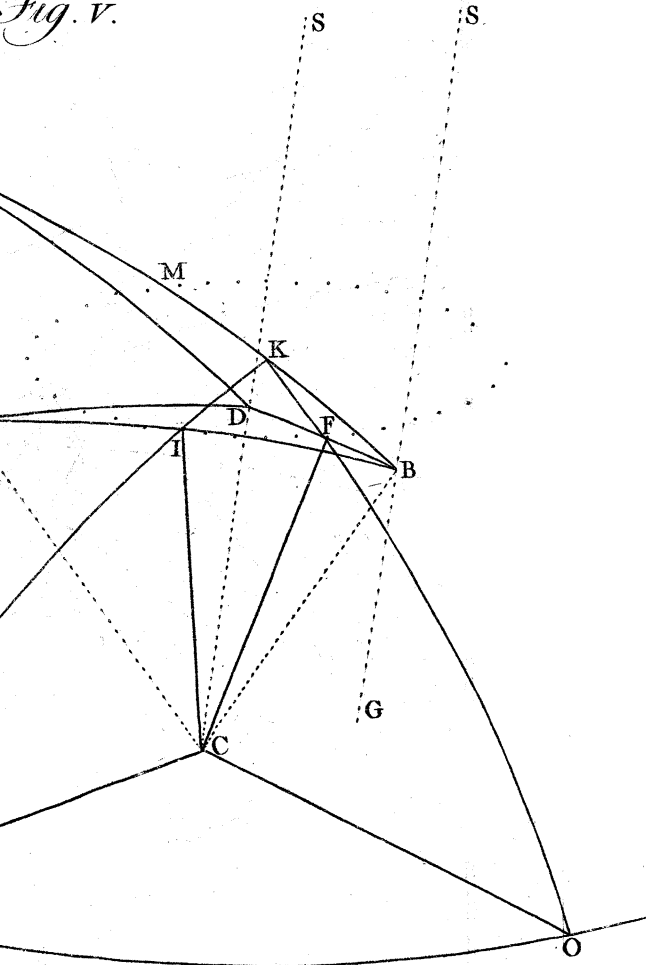

Fig. v.



Fig

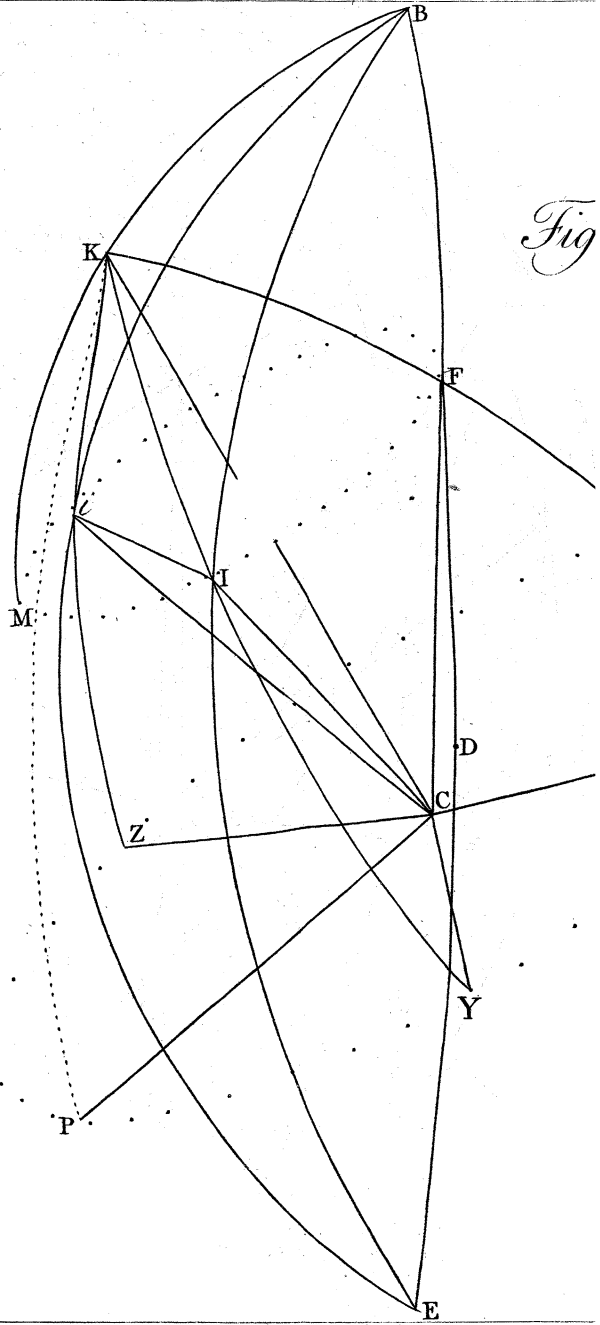
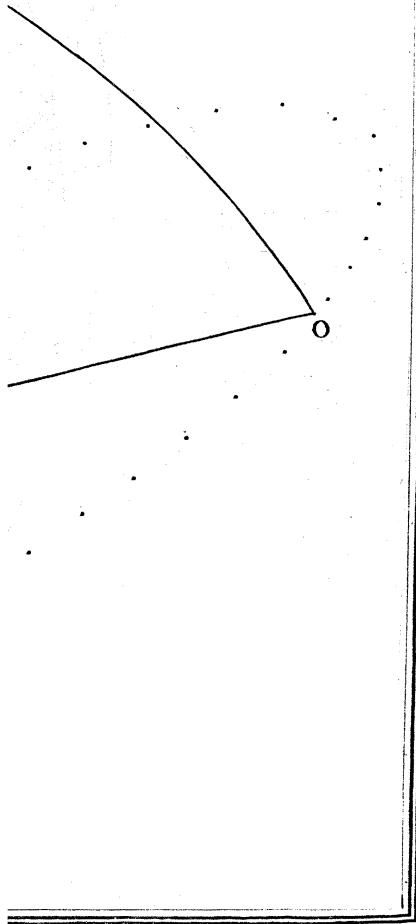

Fig. VI.



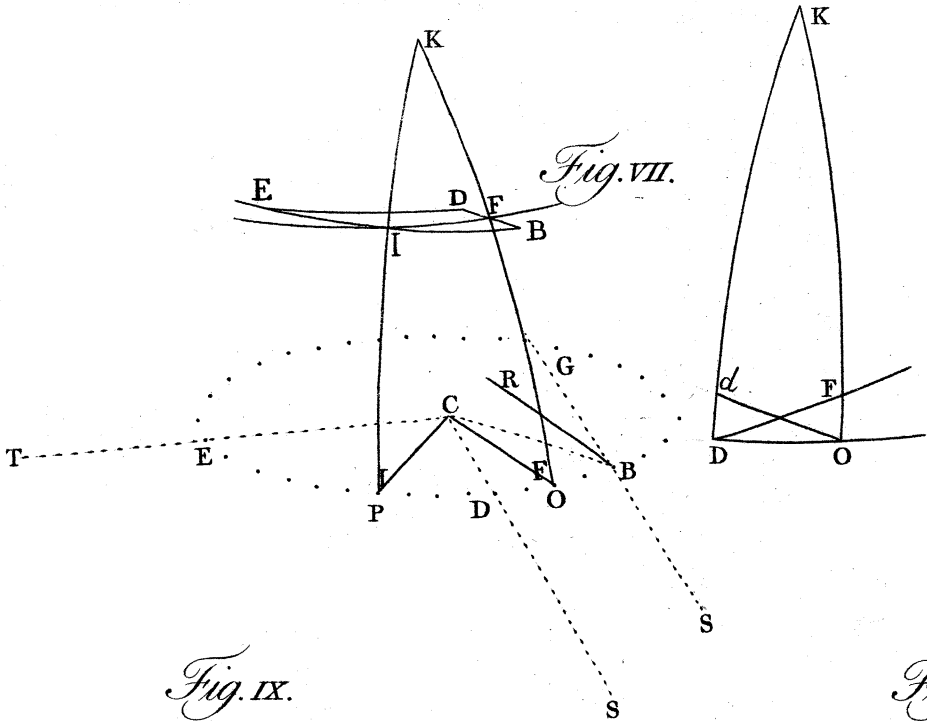

Fig. IX.

Fig. X.

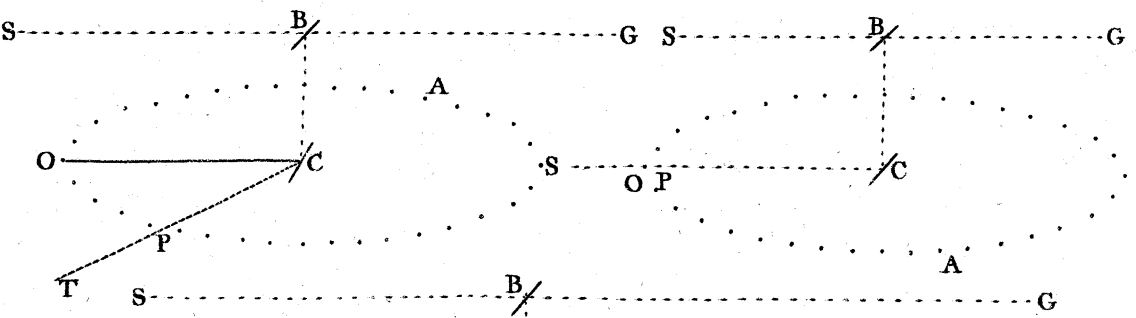

Fig. XI.

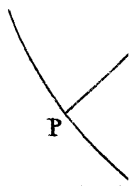
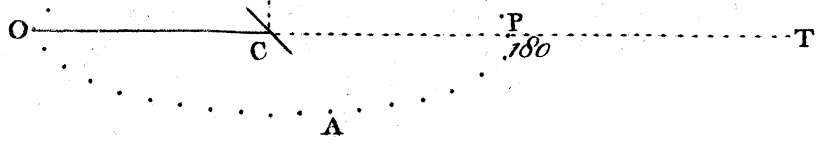

Fig. VIII.

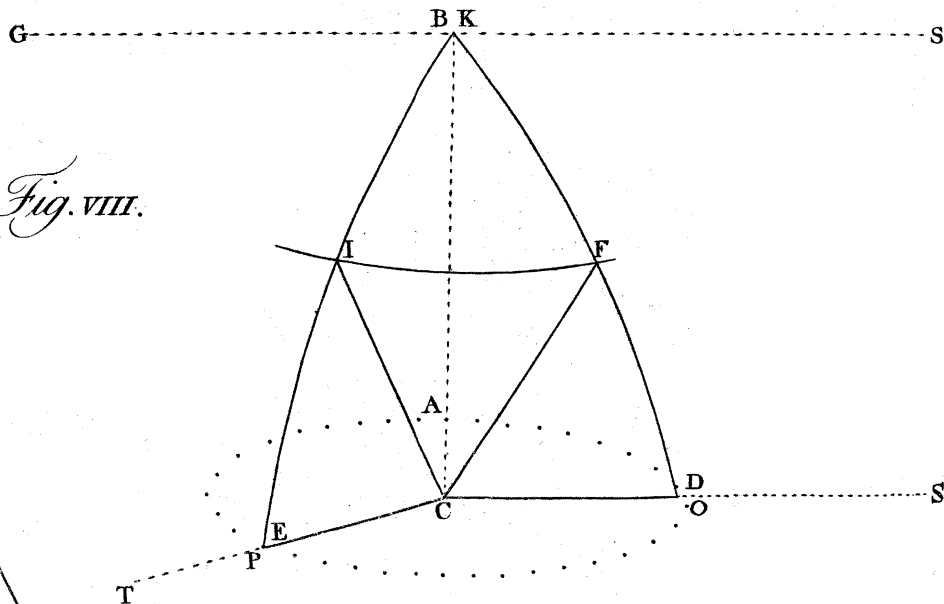

Fig. XII.

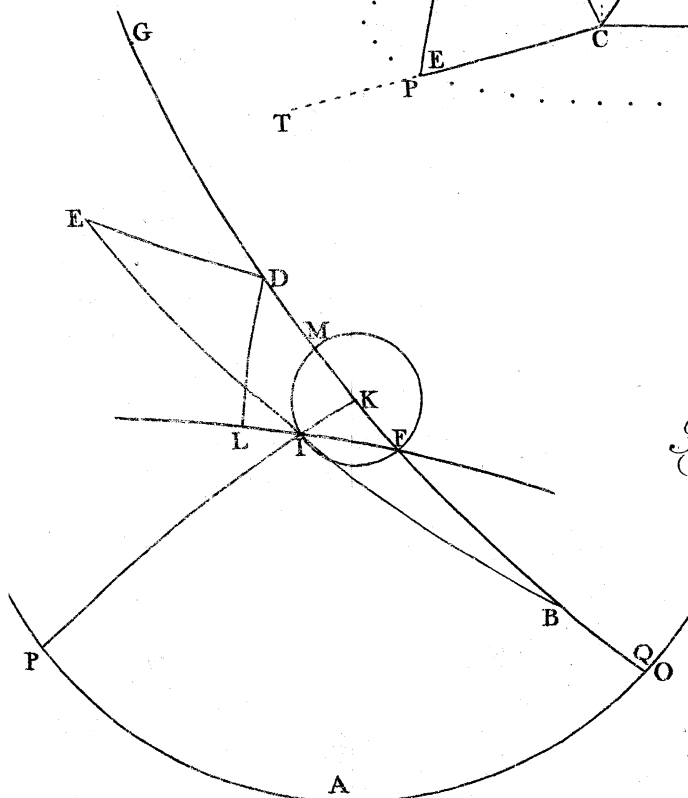

Fig. XIV.

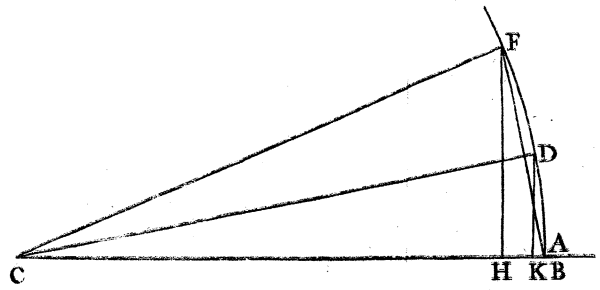
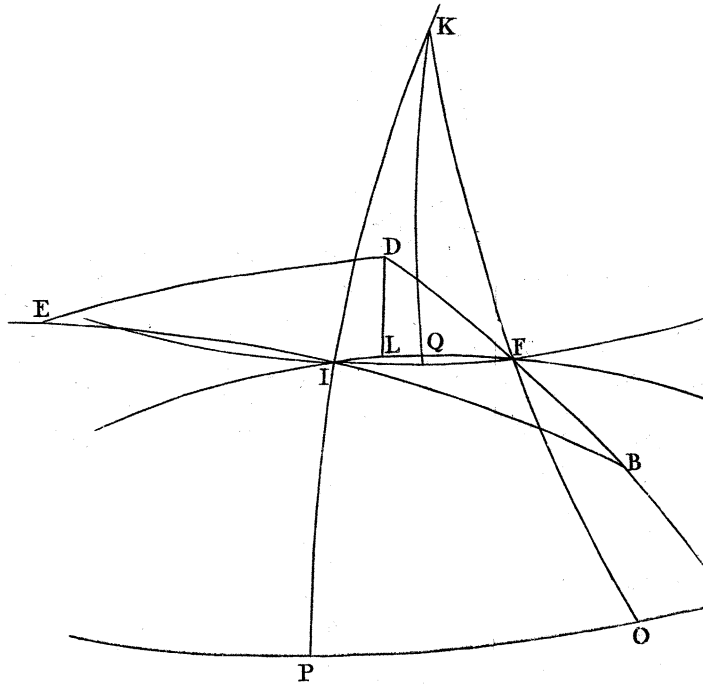

Fig. XIII.

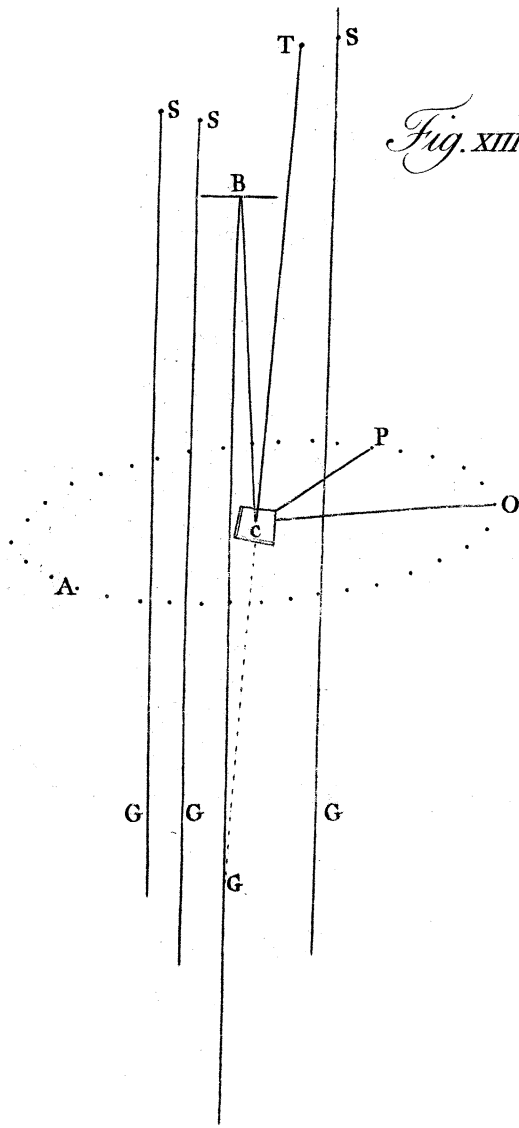

Fig. XV.

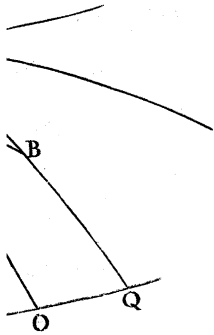
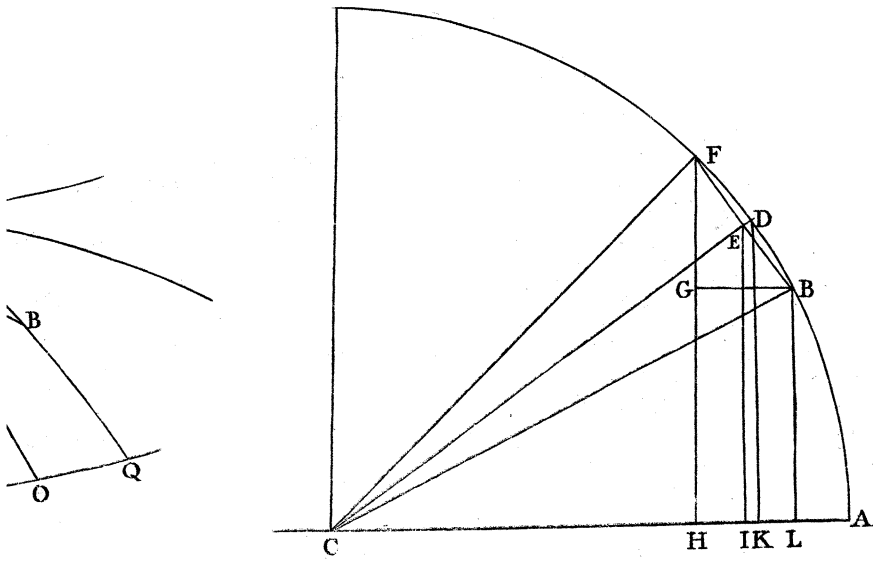

Fig. XVI.

T A B L E III.

Arc pointed to by the index.	Observed angle.	Diff.
100°	1 31 39	40
101°	1 32 19	40
102°	1 32 59	40
103°	1 33 39	39
104°	1 34 18	38
105°	1 34 56	38
106°	1 35 34	38
107°	1 36 12	38
108°	1 36 50	37
109°	1 37 27	36
110°	1 38 3	

T A B L E IV.

Arc pointed to by the index.	Observed angle.	Diff.
100°	30 38 23	13 24
101°	30 51 47	13 15
102°	31 5 2	13 7
103°	31 18 9	12 58
104°	31 31 7	12 49
105°	31 43 56	12 41
106°	31 56 37	12 32
107°	32 9 9	12 23
108°	32 21 32	12 14
109°	32 33 46	12 6
110°	32 45 52	

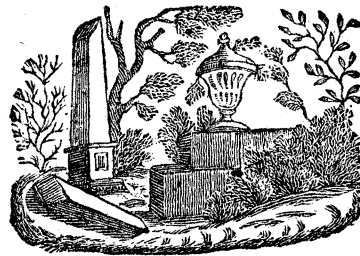

Fig. I.

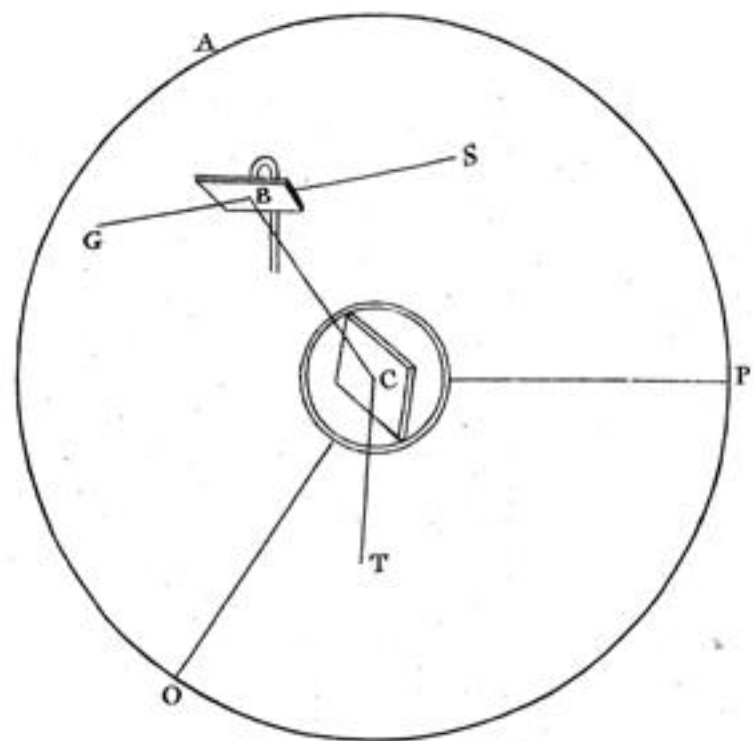

Fig. II.

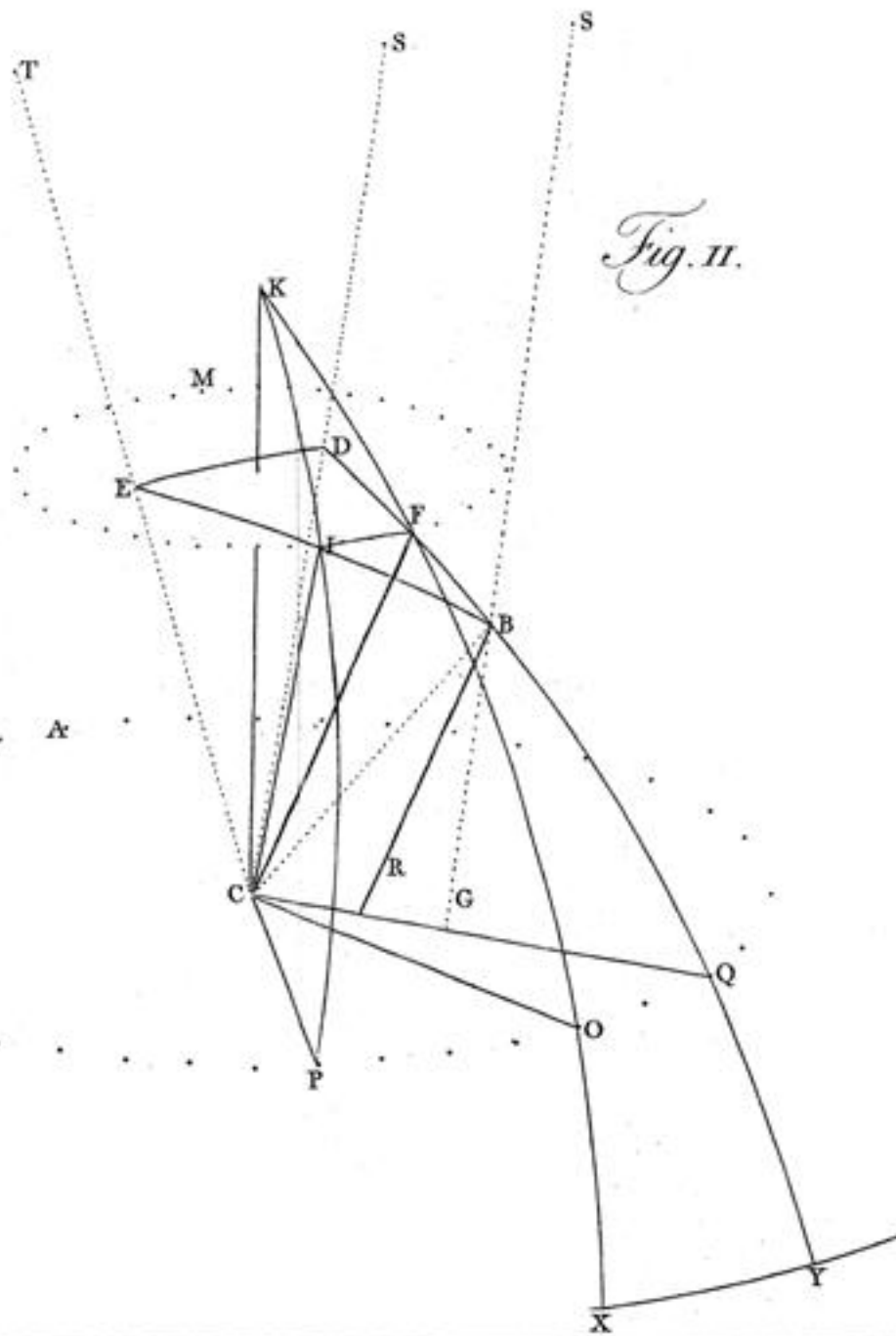

Fig. III.

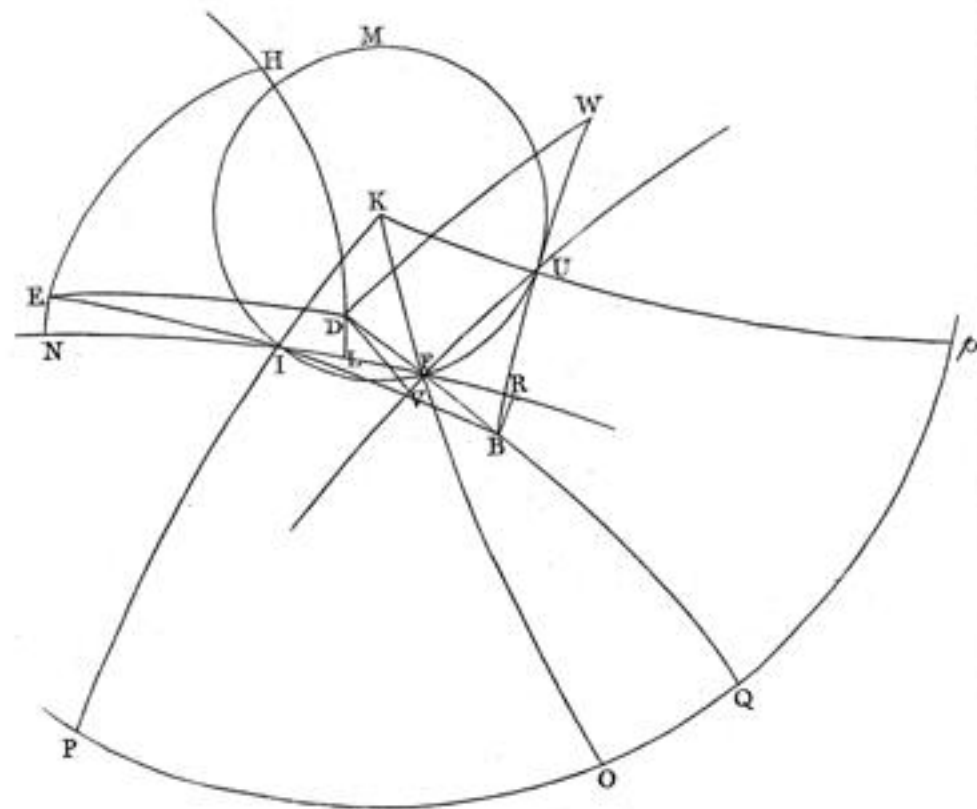

Fig. IV.

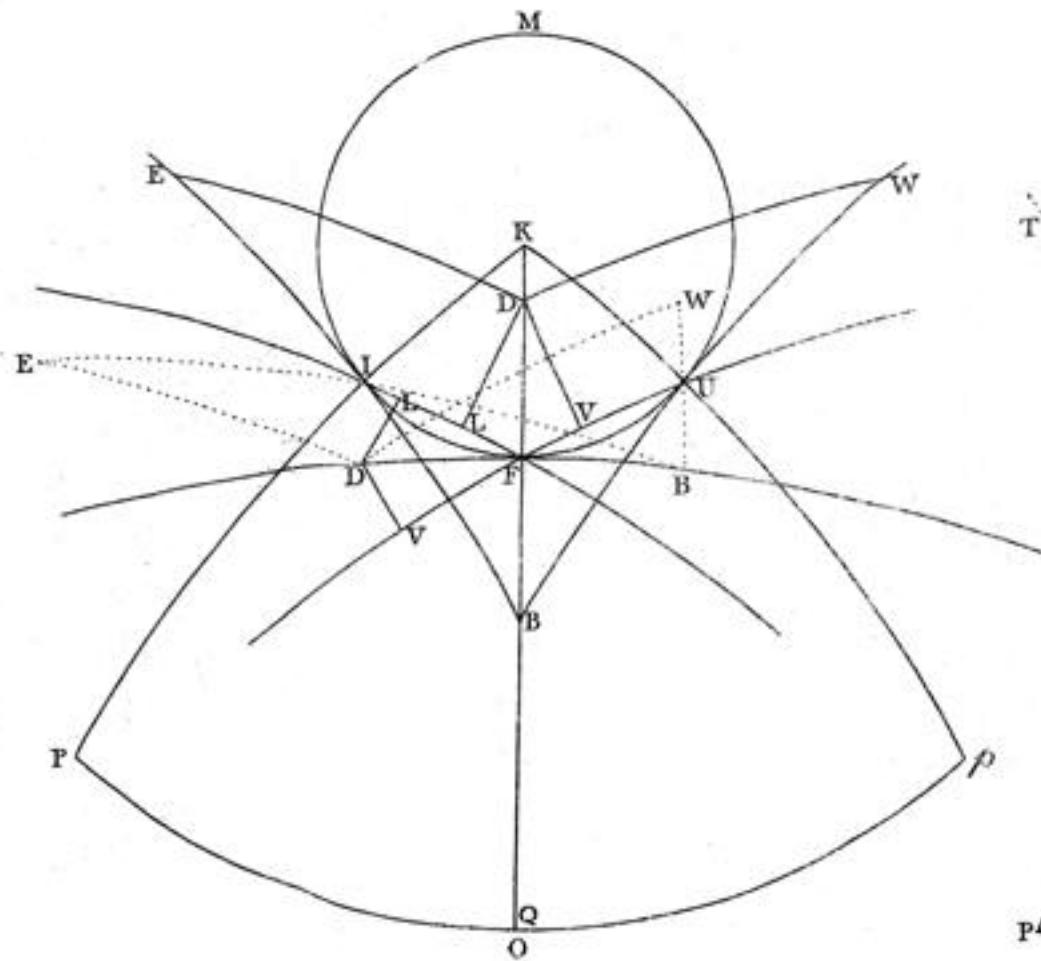

Fig. V.

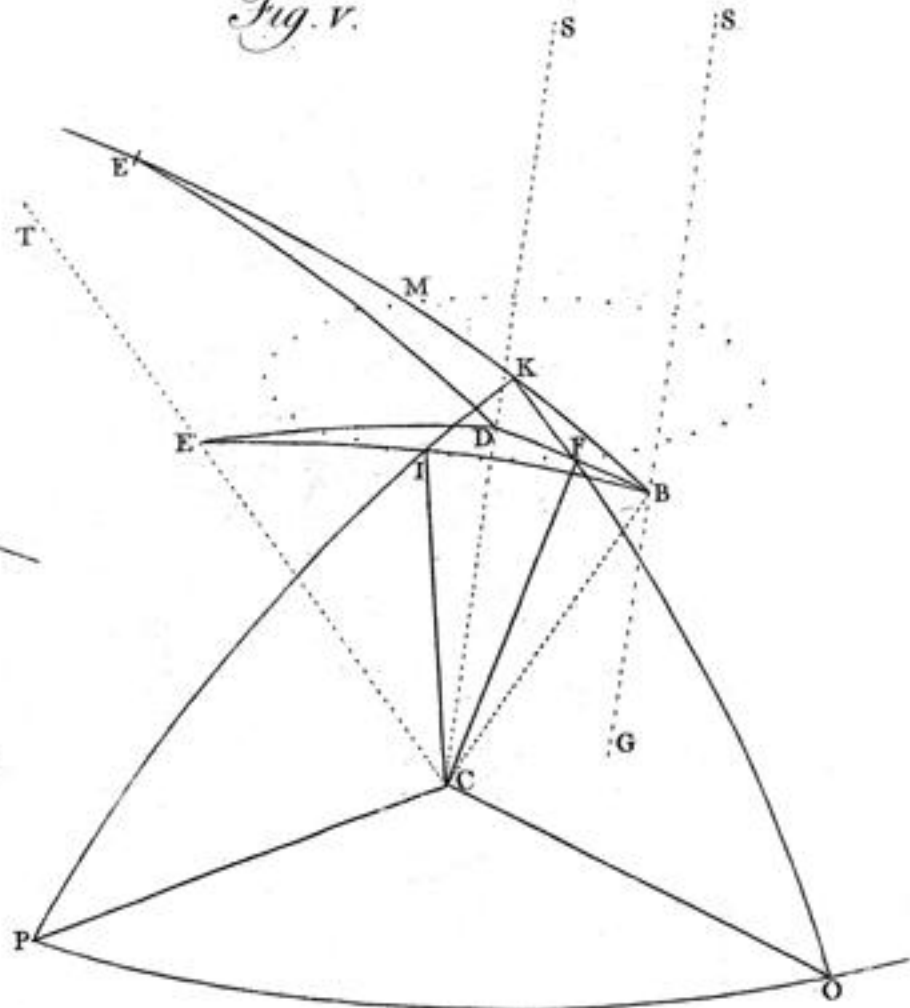
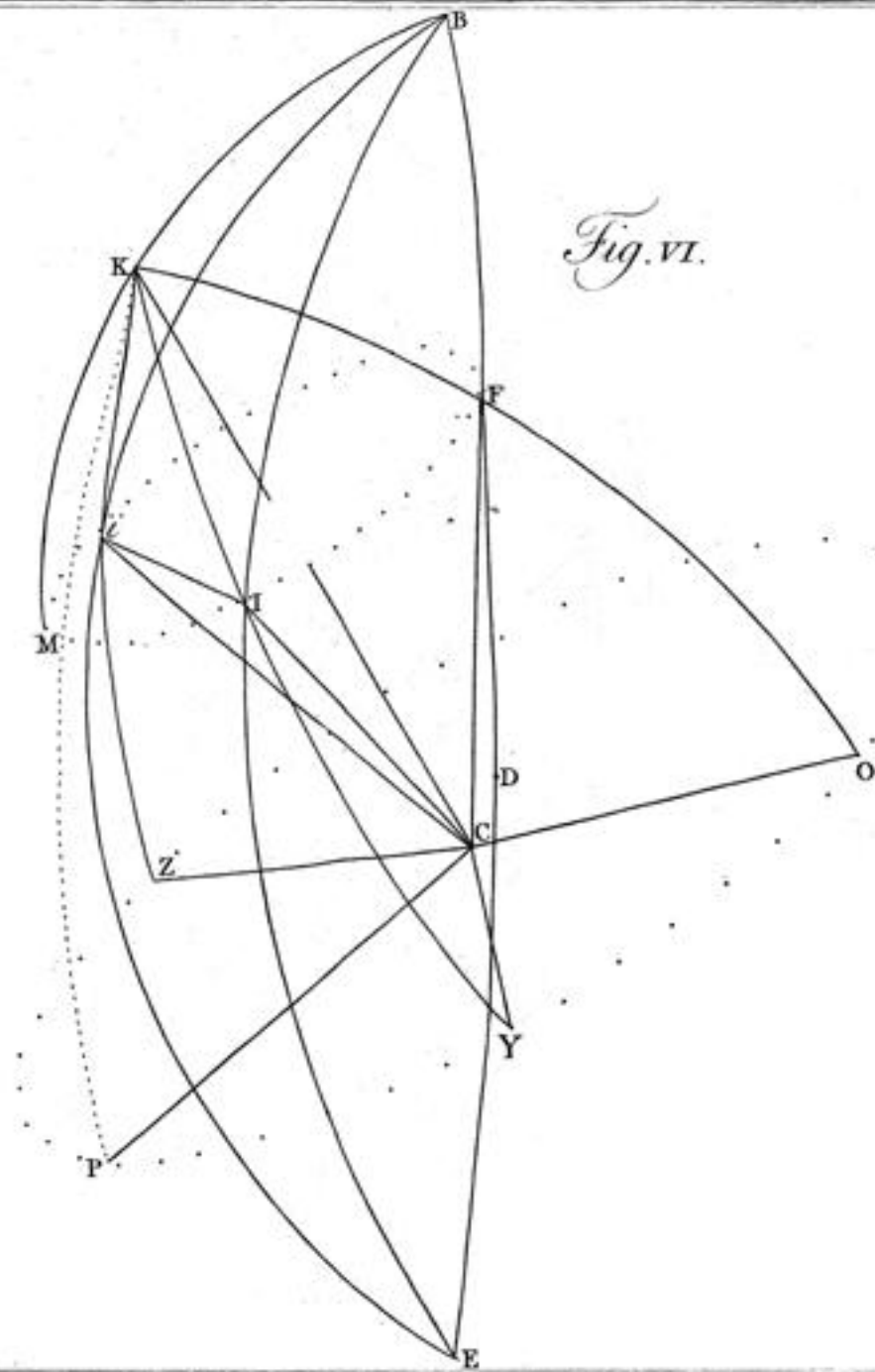
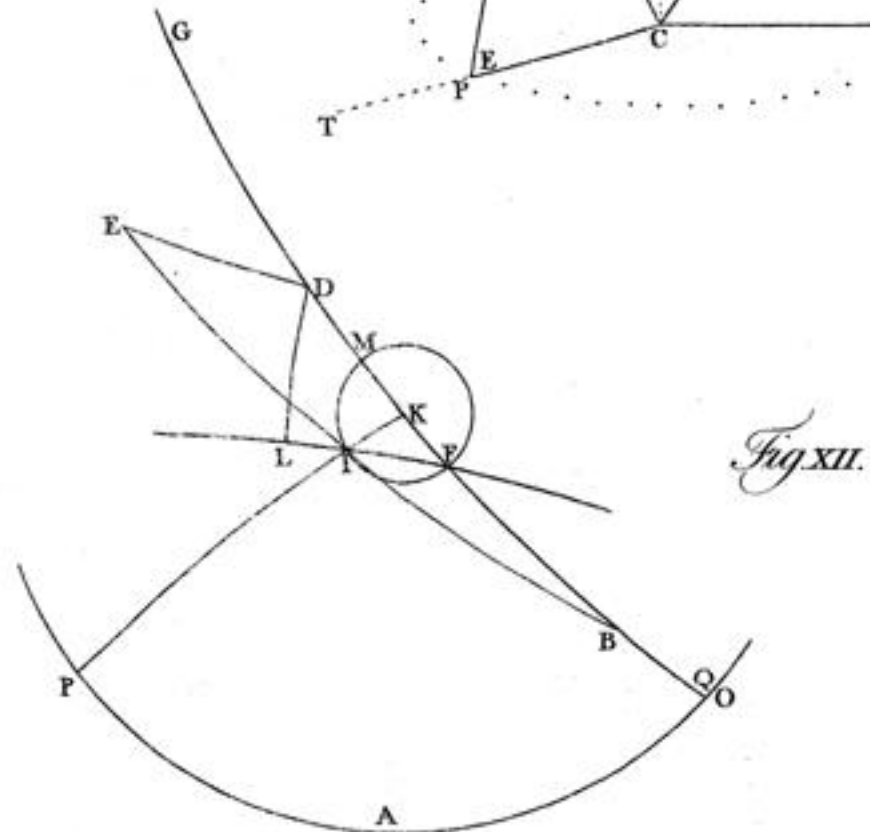
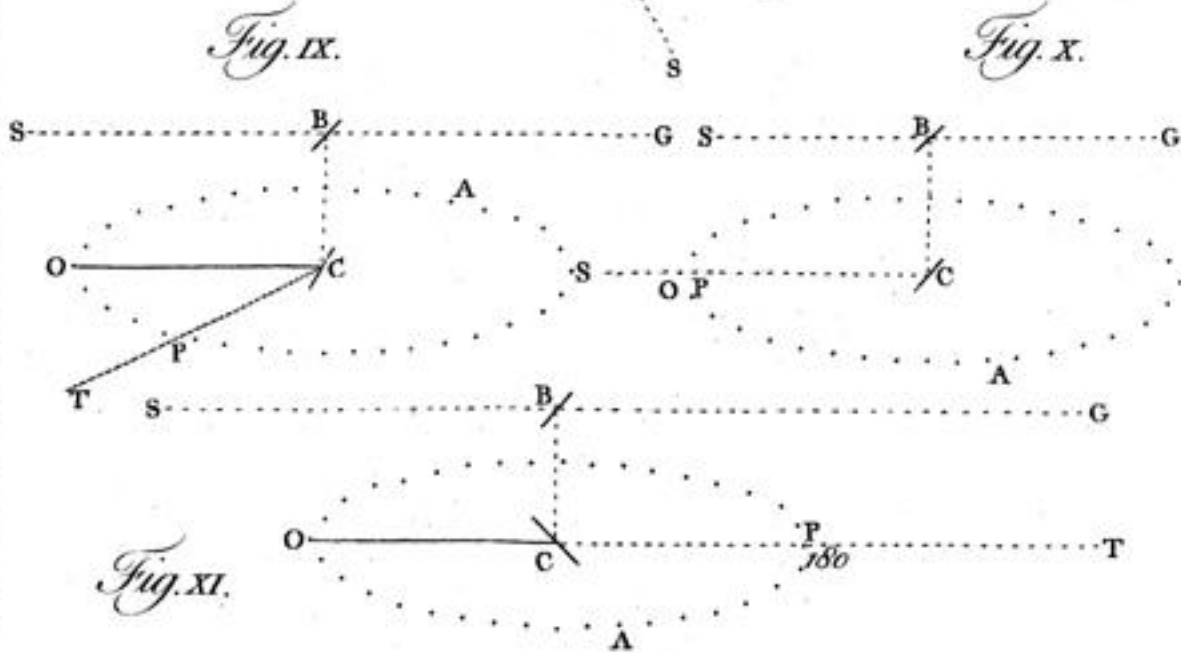
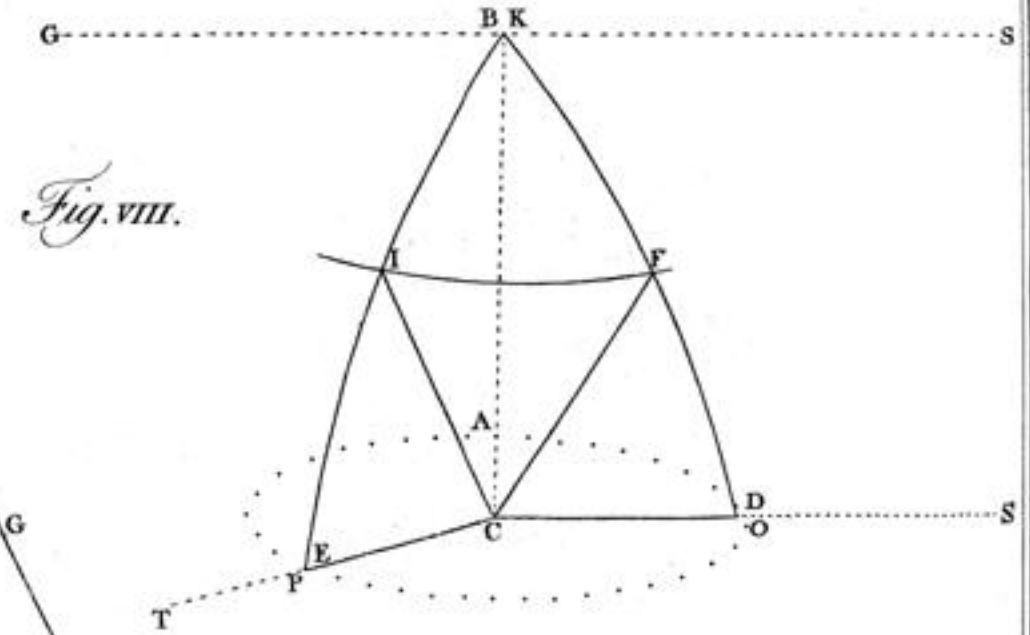
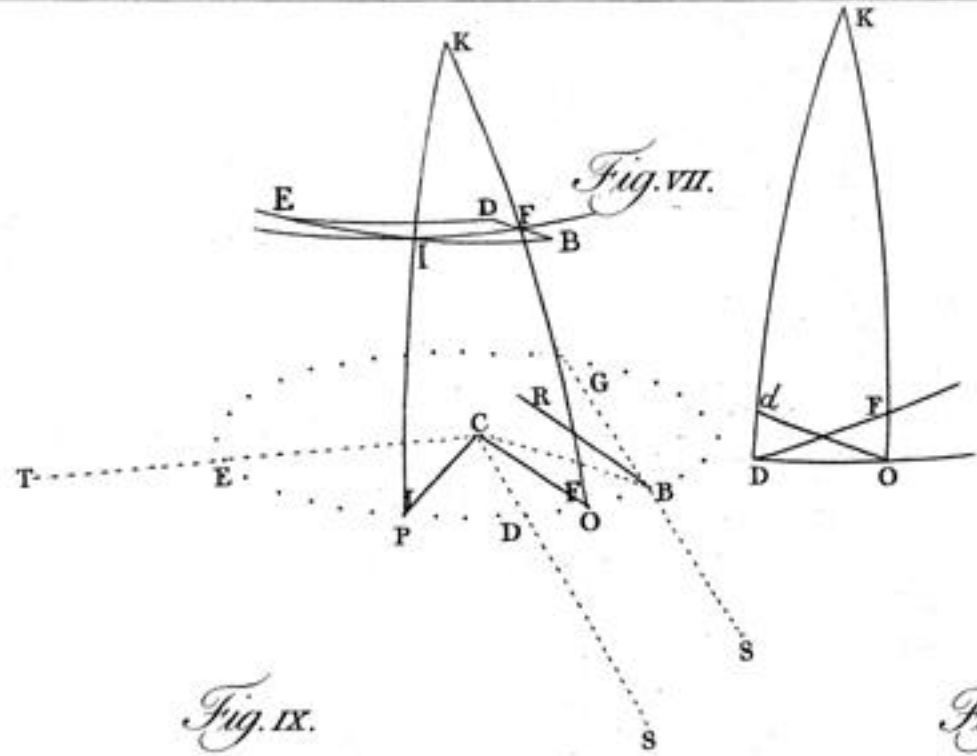

Fig. VI.





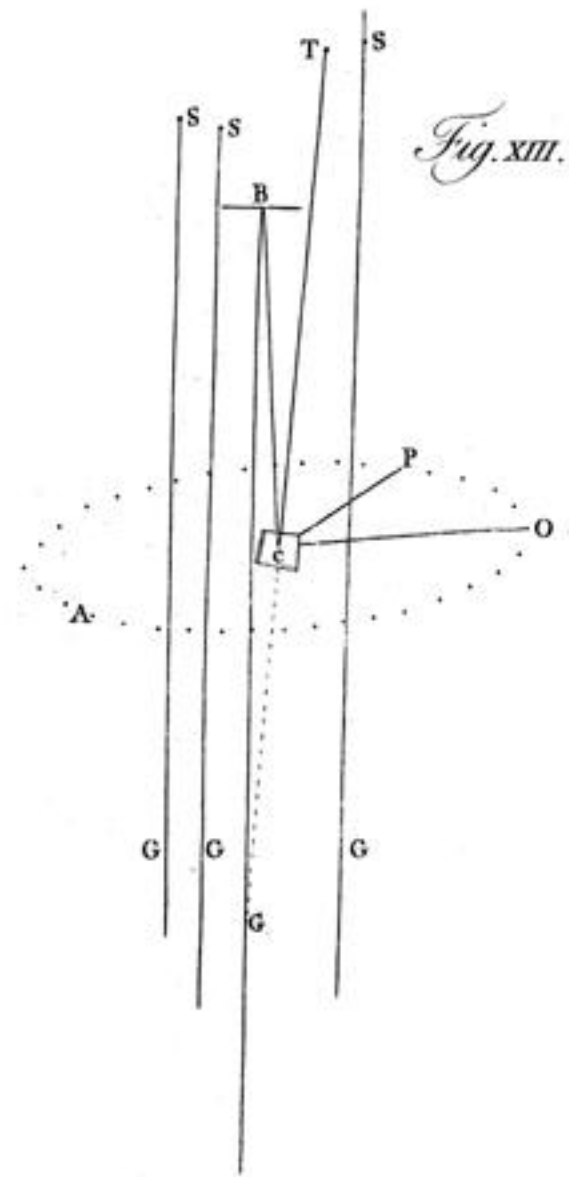

Fig. XIII.

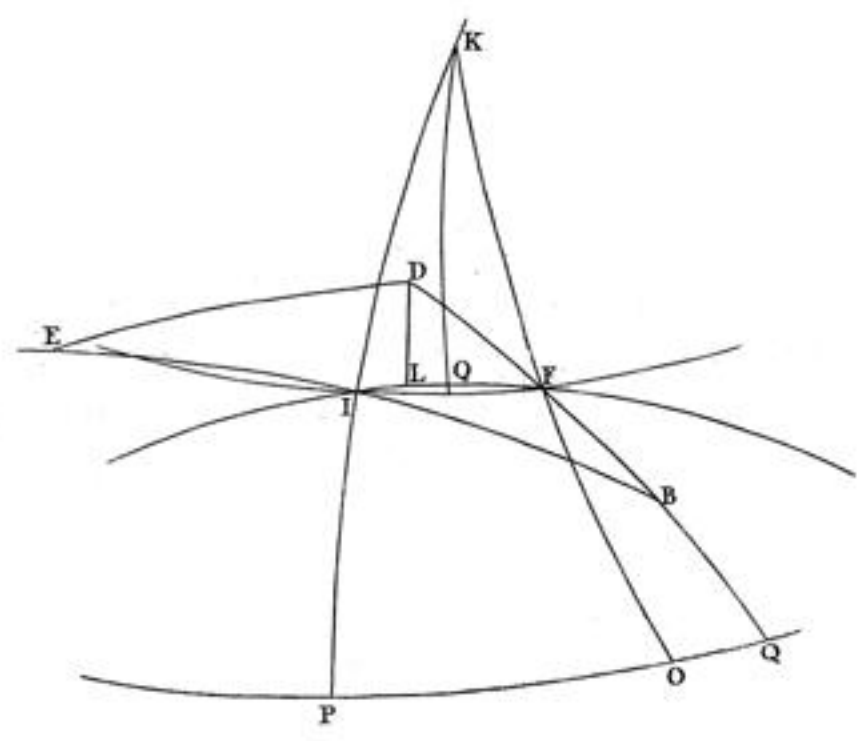

Fig. XIV.

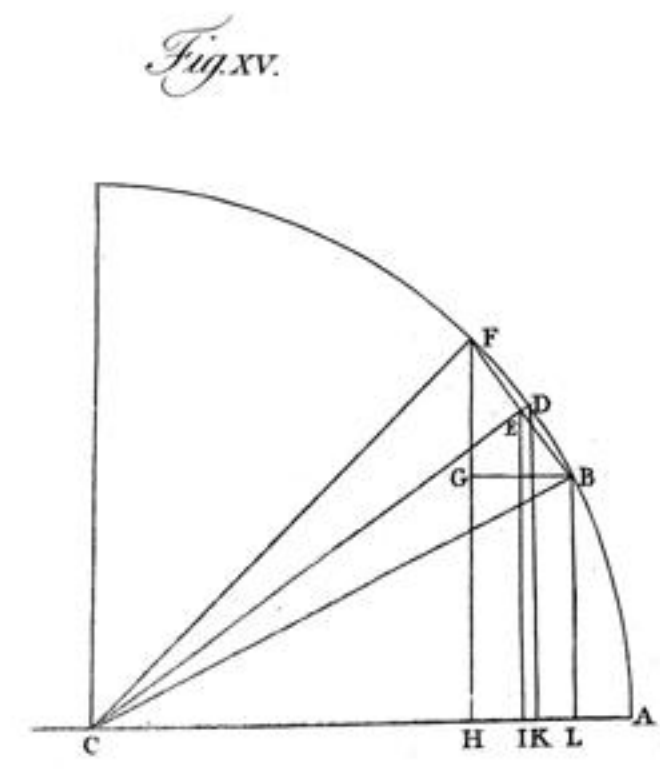

Fig. XV.

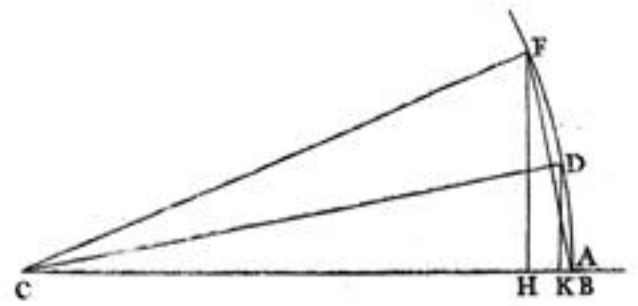

Fig. XVI.